



# User Manual

## SAJ Solar Inverter

R6-15K/17K/20K/22K/25K-T2-32

R6-35K/30K/33K/36K-T3-32

R6-40K/50K-T4-32

R6-5K/6K/8K/10K/15K-T2-32-LV

R6-20K-T3-32-LV

R6-25K/30K-T4-32-LV



## **Preface**

Thank you for choosing SAJ solar inverter. We are pleased to provide you first-class products and exceptional service.

This manual includes information for installation, operation, maintenance, trouble shooting and safety. Please follow the instructions of this manual so that we can ensure delivery of our professional guidance and wholehearted service.

Customer-orientation is our forever commitment. We hope this document proves to be of great assistance in your journey for a cleaner, greener world. Please check for the latest version at [www.saj-electric.com](http://www.saj-electric.com)

Guangzhou Sanjing Electric Co., Ltd.

**Building e-Energy Management Solution Provider**

# Content

<b>PREFACE</b> .....	- 1 -
<b>CHAPTER 1 SAFETY PRECAUTIONS</b> .....	- 5-
1.1 SCOPE OF APPLICATION .....	- 5 -
1.2 SAFETY INSTRUCTIONS.....	- 5 -
1.3 TARGET GROUP .....	- 6 -
<b>CHAPTER 2 PREPARATION</b> .....	- 6 -
2.1 SAFETY INSTRUCTIONS.....	- 6 -
2.2 EXPLANATIONS OF SYMBOLS .....	- 8 -
<b>CHAPTER 3 PRODUCT INFORMATION</b> .....	- 9 -
3.1 APPLICATION SCOPE OF PRODUCTS.....	- 9 -
3.2 SPECIFICATION FOR PRODUCT MODEL .....	- 10 -
3.3 OVERVIEW OF PRODUCTS.....	- 10 -
3.4 DATASHEET .....	- 12 -
<b>CHAPTER 4 INSTRUCTIONS FOR INSTALLATION</b> .....	- 20 -
4.1 SAFETY INSTRUCTIONS.....	- 20 -
4.2 PRE-INSTALLATION CHECK.....	- 20 -
4.3 THE DETERMINATION OF THE INSTALLATION METHOD AND POSITION ....	- 21 -
4.4 MOUNTING PROCEDURE .....	- 22 -
<b>CHAPTER 5 ELECTRICAL CONNECTION</b> .....	- 27-
5.1 SAFETY INSTRUCTION FOR HOT-LINE JOB .....	- 27 -
5.2 SPECIFICATIONS FOR ELECTRICAL INTERFACE .....	- 28 -
5.3 AC CONNECTION .....	- 30 -
5.5 COMMUNICATION CONNECTION.....	- 34 -

---

<b>CHAPTER 6 DEBUGGING INSTRUCTIONS .....</b>	<b>- 37 -</b>
<b>6.1 INTRODUCTION OF HMI (HUMAN-MACHINE INTERFACE) .....</b>	<b>- 37 -</b>
<b>6.2 MONITORING OPERATION.....</b>	<b>- 38 -</b>
<b>CHAPTER 7 FAULT CODE AND TROUBLESHOOTING .....</b>	<b>- 44 -</b>
<b>CHAPTER 8 RECYCLING AND DISPOSAL .....</b>	<b>- 48 -</b>
<b>CHAPTER 9 CONTACT SAJ .....</b>	<b>- 49 -</b>
<b>SAJ WARRANTY POLICY .....</b>	<b>- 50 -</b>
<b>WARRANTY CARD .....</b>	<b>- 53 -</b>

# Chapter 1 Safety Precautions

## 1.1 Scope of Application

This User Manual describes instructions and detailed procedures for installing, operating, maintaining, and troubleshooting of the following SAJ on-grid inverters:

R6-15K-T2-32;	R6-17K-T2-32;	R6-20K-T2-32;	R6-22K-T2-32;
R6-25K-T2-32;	R6-25K-T3-32;	R6-30K-T3-32;	R6-33K-T3-32;
R6-36K-T3-32;	R6-40K-T4-32;	R6-50K-T4-32	
R6-5K-T2-32-LV;	R6-6K-T2-32-LV;	R6-8K-T2-32-LV;	
R6-10K-T2-32-LV;	R6-15K-T2-32-LV;	R6-20K-T3-32-LV	
R6-25K-T4-32-LV;	R6-30K-T4-32-LV;		

Please keep this manual all time available in case of emergency.

## 1.2 Safety Instructions



### DANGER

· DANGER indicates a hazardous situation which, if not avoided, will result in death or serious injury.



### WARNING

· WARNING indicates a hazardous situation which, if not avoided, can result in death or serious injury or moderate injury.



### CAUTION

· CAUTION indicates a hazardous condition which, if not avoided, can result in minor or moderate injury.



### NOTICE

· NOTICE indicates a situation that can result in potential damage, if not avoided.

## 1.3 Target Group

Only qualified electricians who have read and fully understood all safety regulations contained in this manual can install, maintain and repair the inverter. Operators must be aware of the high-voltage device.

# Chapter 2 Preparation

## 2.1 Safety Instructions



### DANGER

- There is possibility of dying due to electrical shock and high voltage.
- Do not touch the operating component of the inverter, it might result in burning or death.
- To prevent risk of electric shock during installation and maintenance, please make sure that all AC and DC terminals are plugged out.
- Do not touch the surface of the inverter while the housing is wet, otherwise, it might cause electrical shock.
- Do not stay close to the inverter while there are severe weather conditions including storm, lightning, etc.
- Before opening the housing, the SAJ inverter must be disconnected from the grid and PV generator; you must wait for at least five minutes to let the energy storage capacitors completely discharged after disconnecting from power source.



### WARNING

- The installation, service, recycling and disposal of the inverters must be performed by qualified personnel only in compliance with national and local standards and regulations.
- Any unauthorized actions including modification of product functionality of any form may cause lethal hazard to the operator, third parties, the units or their property. SAJ is not responsible for the loss and these warranty claims.
- The SAJ inverter must only be operated with PV generator. Do not connect any other source of energy to the SAJ inverter.
- Be sure that the PV generator and inverter are well grounded in order to protect properties and persons.











**CAUTION**

- The solar inverter will become hot during operation. Please do not touch the heat sink or peripheral surface during or shortly after operation.
- Risk of damage due to improper modifications.

**NOTICE**

- Public utility only.
- The solar inverter is designed to feed AC power directly to the public utility power grid; do not connect AC output of the inverter to any private AC equipment.

## 2.2 Explanations of Symbols

Symbol	Description
	<b>Dangerous electrical voltage</b> This device is directly connected to public grid, thus all work to the inverter shall only be carried out by qualified personnel.
	<b>Danger to life due to high electrical voltage!</b> There might be residual currents in inverter because of large capacitors. Wait for 5 minutes before you remove the front lid.
	<b>Notice, danger!</b> This is directly connected with electricity generators and public grid.
	<b>Danger of hot surface</b> The components inside the inverter will release a lot of heat during operation. Do not touch metal plate housing during operating.
	<b>An error has occurred</b> Please go to Chapter 9 “Troubleshooting” to remedy the error.
	<b>This device shall not be disposed of in residential waste</b> Please go to Chapter 8 “Recycling and Disposal” for proper treatments.
	<b>Without Transformer</b> This inverter does not use transformer for the isolation function.
	<b>CE Mark</b> Equipment with the CE mark fulfills the basic requirements of the Guideline Governing Low-Voltage and Electro-magnetic Compatibility.
	<b>CQC Mark</b> The inverter complies with the safety instructions from China's Quality Center.
 <b>ATTENTION</b> Risk of electric shock! Only authorized operations are allowed to do disassembly, modification or maintenance. Any resulting defect or damage (device/person) is not covered by SAJ warranty.	<b>No unauthorized operations or modifications</b> Any unauthorized operations or modifications are strictly forbidden, if any defect or damage (device/person) occurs, SAJ shall not take any responsibility for it.



## Chapter 3 Product Information

### 3.1 Application Scope of Products

R6-XX-TX-32 / R6-XX-TX-32-LV products are grid-tied three phase inverters without transformers, and the inverters are important components of grid-tied solar power systems.

The R6 inverter converts the DC generated by solar panels into AC which is in accordance with the requirements of public grid and send the AC into the grid, Figure 3.1 shows the structural diagram of the typical application system of R6 inverter.



Figure 3.1 R6 series application

Name	Description	Remarks
A	Solar panels	Monocrystalline or polycrystalline silicon, and thin-film PV modules with II protection and need no ground connection
B	Inverters	R6-15k/17K/20K/22K/25K-T2-32; R6-25K/30K/33K/36K-T3-32; R6-40K/50K-T4-32; R6-5K/6K/8K/10K/15K-T2-32-LV; R6-20K-T3-32-LV; R6-25K/30K-T4-32-LV
C	Metering equipment	Standard metering tool for measuring the output electric power of inverters
D	Power grid	TT, TN-C, TN-S, TN-C-S

### 3.2 Specification for Product Model

R6 – XK – TX – 32 – LV  
 ①      ②      ③      ④      ⑤

- ① R6 represents for product name.
- ② XK represents rated power XkW of inverter, for example 4K means 4kW.
- ③ T means three phase; X represents the inverter has the function of X MPP trackers.
- ④ 32 means that max. DC input current of per MPP tracker is 32A.
- ⑤ LV means that nominal AC output voltage is 127V(F-N)/220V(F-F).

### 3.3 Overview of products

The dimensions of R6 series products is shown in Figure 3.2 , Figure 3.3 & Figure 3.4.

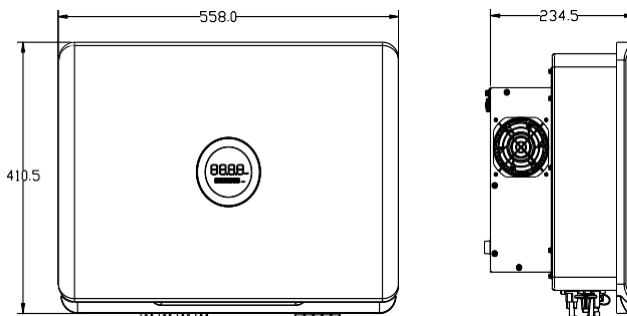

Figure 3.2 Dimensions of R6-15K/17K/20K/22K/25K-T2-

32; R6-5K/6K/8K/10K/15K-T2-32-LV

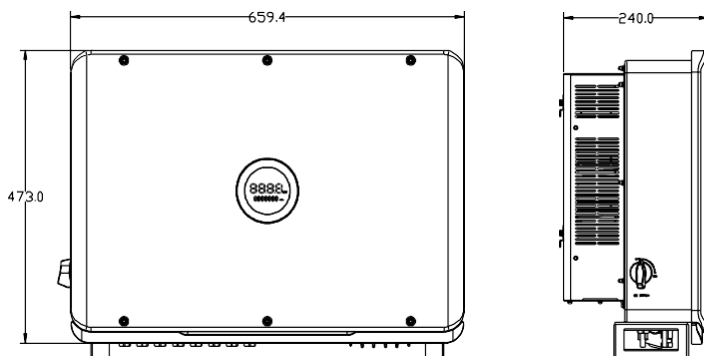

Figure 3.3 Dimensions of R6-25K/30K/33K/36K-T3-32;  
R6-20K-T3-32-LV

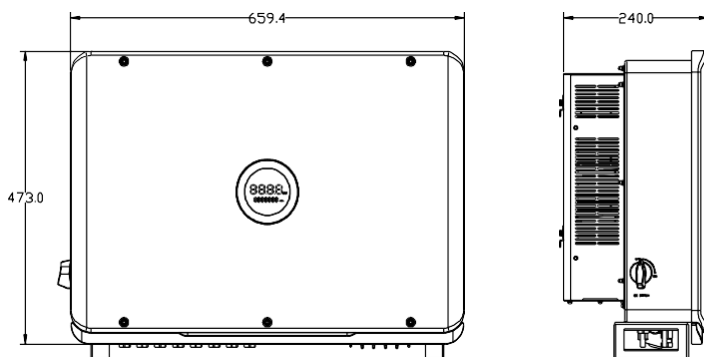

Figure 3.4 Dimensions of R6-40K/50K-T4-  
32; R6-25K/30K-T4-32-LV

### 3.4 Datasheet

#### R6-15K/17K/20K/22K/25K-T2-32

Model	R6-15K-T2-32	R6-17K-T2-32	R6-20K-T2-32	R6-22K-T2-32	R6-25K-T2-32
<b>Input (DC)</b>					
Max. PV Array Power [Wp]@STC	22500	25500	30000	33000	37500
Max. Input Voltage [V]	1100				
MPP Voltage Range [V]	180-1000				
Nominal Input Voltage [V]	600				
Start-up Voltage [V]	200				
Max. Input Current [A]	32/32				
Number of MPP Trackers	2				
Number of Strings per MPP Tracker	2/2				
<b>Output (AC)</b>					
Rated AC Output Power [W]	15000	17000	20000	22000	25000
Max. Apparent Power [VA] * <sup>1</sup>	16500	18700	22000	24200	27500
Rated AC Output Current [A]@230Vac	21.7	24.6	29	31.9	36.2
Max. AC Output Current [A]	25.0	28.4	33.4	36.7	41.7
Nominal AC Voltage/ Range [V]	220(F-N)/380(F-F); 180-280(F-N)/312-485(F-F)				
Nominal AC Grid Frequency/ Range [Hz]	50, 60/44-55, 54-65				
Total Distortion Harmonic [THDi]	< 3%				
Power Factor	0.8 leading~0.8 lagging				
Feed-in Phases/AC Connection Phases	3/3				
<b>Efficiency</b>					
Max. Efficiency	98.8%				
Euro Efficiency	98.5%				
<b>Protection</b>					
DCI Monitoring	Integrated				
GFCI Monitoring	Integrated				
Grid Monitoring	Integrated				
AC Grounding Detection	Integrated				
AC Short-Circuit Protection	Integrated				
DC Insulation Resistance Detection	Integrated				
DC Surge Protection	Type III				

AC Surge Protection	Type III
Anti-islanding Protection	AFD
AFCI Protection	Optional
<b>Interface</b>	
AC Connection	Terminal Block
DC Connection	MC4
Display	LED+APP (Bluetooth)
Communication Port	RS232+RS485 (RJ45)+DRM(RJ45)
Communication Mode	Wi-Fi/Ethernet//4G
Load Monitoring	24/7 (Optional)
<b>General Data</b>	
Topology	Transformerless
Nighttime Power Consumption [W]	<0.6
Operating Temperature Range	-40°C~+60°C
Cooling Method	Intelligent fan Cooling
Ambient Humidity	0%~100% non-condensing
Max. Operating Altitude [m]	4000m (>3000m power derating)
Noise [dBA]	<50
Ingress Protection	IP65
Mounting	Rear Panel
Dimensions [H*W*D] [mm]	558*409*234
Weight [kg]	23.7
Warranty [Year]	5 (Standard)/10/15/20/25 (Optional)
Certifications	IEC/EN62109-1/2, EN61000-6-1/2/3/4, IEC61683, IEC60068-2, IEC62116, IEC61727, PEA/MEA, VDE0126-1-1/A1, CEI 0-21, VDE-AR-N 4105, AS/NZS4777.2, CQC NB/T 32004, G98/G99, NBR 16149, NBR 16150, C10/11, RD1669, UNE206006, UNE206007, EN50438

Note: \*1. According to C10/C11, Max. AC Power = Rated AC Power

2. The above parameters might be slightly modified according to different grid codes.
3. If you need more information about our product certifications, please contact our sales.

## R6-25K/30K/33K/36K-T3-32, R6-40K/50K-T4-32

Model	R6-25K-T3-32	R6-30K-T3-32	R6-33K-T3-32	R6-36K-T3-32	R6-40K-T4-32	R6-50K-T4-32
<b>Input (DC)</b>						
Max. PV Array Power [Wp]@STC	37500	45000	49500	54000	60000	75000
Max. Input Voltage [V]	1100					
MPP Voltage Range [V]	180-1000					
Nominal Input Voltage [V]	600					
Startup Voltage [V]	200					
Max. Input Current [A]	32/32/32				32/32/32/32	
Number of MPP Trackers	3				4	
Number of Strings per MPP Tracker	2/2/2				2/2/2/2	
<b>Output (AC)</b>						
Rated AC Output Power [W]	25000	30000	33000	36000	40000	50000
Max. Apparent Power [VA] *1	27500	33000	36300	39600	44000	50000
Rated AC Output Current [A]@230Vac	36.2	43.5	47.8	52.2	58	72.5
Max. AC Output Current [A]	41.7	50	55	60	66.7	75.8
Nominal AC Voltage/ Range [V]	220(F-N)/380(F-F); 180-280(F-N)/312-485(F-F)					
Nominal AC Grid Frequency/ Range [Hz]	50, 60 / 44-55, 54-65					
Total Distortion Harmonic [THD]	<3%					
Power Factor	0.8 leading ~ 0.8 lagging					
Feed-in Phase/AC Connection Phases	3/3					
<b>Efficiency</b>						
Max. Efficiency	98.8%					
Euro Efficiency	98.5%					
<b>Protection</b>						
DCI Monitoring	Integrated					
GFCI Monitoring	Integrated					
Grid Monitoring	Integrated					
AC Grounding Detection	Integrated					
AC Short-Circuit Protection	Integrated					
DC Insulation Resistance Detection	Integrated					
DC Surge Protection	Type II					
AC Surge Protection	Type III					
Anti-islanding Protection	AFD					

AFCI Protection	Optional		
<b>Interface</b>			
AC Connection	Terminal Block		
DC Connection	MC4		
Display	LED+APP (Bluetooth)		
Communication Port	RS232+RS485 (RJ45)+DRM(RJ45)		
Communication Mode	Wi-Fi/Ethernet//4G		
Load Monitoring	24/7 (Optional)		
<b>General Data</b>			
Topology	Transformerless		
Nighttime Power Consumption [W]	<0.6		
Operating Temperature Range	-40°C ~ +60°C		
Cooling Method	intelligent fan Cooling		
Ambient Humidity	0% ~ 100% non-condensing		
Max. Operating Altitude [m]	4000m (>3000m power derating)		
Noise [dBA]	<50		
Ingress Protection	IP65		
Mounting	Rear Panel		
Dimensions [H*W*D] [mm]	659.4*473*240		
Weight [kg]	35.5	37	37.5
Warranty [Year]	5 (Standard)/10/15/20/25 (Optional)		
Certifications	IEC/EN62109-1/2, EN61000-6-1/2/3/4, IEC61683, IEC60068-2, IEC62116, IEC61727, PEA/MEA, VDE0126-1-1/A1, CEI 0-21, VDE-AR-N 4105, AS/NZS4777.2, CQC NB/T 32004, G98/G99, NBR 16149, NBR 16150, C10/11, RD1669, UNE206006, UNE206007, EN50438		

Note: \*1. According to C10/C11, Max. AC Power = Rated AC Power

2. The above parameters might be slightly modified according to different grid codes.
3. If you need more information about our product certifications, please contact our sales.

## R6-5K/6K/8K/10K/15K-T2-32-LV

Model	R6-5K-T2-32-LV	R6-6K-T2-32-LV	R6-8K-T2-32-LV	R6-10K-T2-32-LV	R6-15K-T2-32-LV
<b>Input (DC)</b>					
Max. PV Array Power [Wp]@STC	7500	9000	12000	15000	22500
Max. Input Voltage [V]	1100				
MPP Voltage Range [V]	180-1000				
Nominal Input Voltage [V]	370				
Start-up Voltage [V]	200				
Max. Input Current [A]	32/32				
Number of MPP Trackers	2				
Number of Strings per MPP Tracker	2/2				
<b>Output (AC)</b>					
Rated AC Output Power [W]	5000	6000	8000	10000	15000
Max. Apparent Power [VA] * <sup>1</sup>	5500	6600	8800	11000	15000
Rated AC Output Current [A]@230Vac	13.1	15.7	21	26.2	39.4
Max. AC Output Current [A]	14.4	17.3	23.1	28.9	39.4
Nominal AC Voltage/ Range [V]	127V(F-N)/220V(F-F); 101.6-139.7(F-N)				
Nominal AC Grid Frequency/Range [Hz]	50, 60/44-55, 54-65				
Total Distortion Harmonic [THDi]	< 3%				
Power Factor	0.8 leading~0.8 lagging				
Feed-in Phases/AC Connection Phases	3/3				
<b>Efficiency</b>					
Max. Efficiency	98.8%				
Euro Efficiency	98.5%				
<b>Protection</b>					
DCI Monitoring	Integrated				
GFCI Monitoring	Integrated				
Grid Monitoring	Integrated				
AC Grounding Detection	Integrated				
AC Short-Circuit Protection	Integrated				
DC Insulation Resistance Detection	Integrated				
DC Surge Protection	Type III				
AC Surge Protection	Type III				



Anti-islanding Protection	AFD
AFCI Protection	Optional
<b>Interface</b>	
AC Connection	Terminal Block
DC Connection	MC4
Display	LED+APP (Bluetooth)
Communication Port	RS232+RS485 (RJ45)+DRM(RJ45)
Communication Mode	Wi-Fi/Ethernet//4G
Load Monitoring	24/7 (Optional)
<b>General Data</b>	
Topology	Transformerless
Nighttime Power Consumption [W]	<0.6
Operating Temperature Range	-40°C~+60°C
Cooling Method	intelligent fan Cooling
Ambient Humidity	0%~100% non-condensing
Max. Operating Altitude [m]	4000m (>3000m power derating)
Noise [dBA]	<50
Ingress Protection	IP65
Mounting	Rear Panel
Dimensions [H*W*D] [mm]	558*409*234
Weight [kg]	23.7
Warranty [Year]	5 (Standard)/10/15/20/25 (Optional)
Certifications	IEC/EN62109-1/2, EN61000-6-1/2/3/4, IEC61683, IEC60068-2, IEC62116, IEC61727, PEA/MEA, VDE0126-1-1/A1, CEI 0-21, VDE-AR-N 4105, AS/NZS4777.2, CQC NB/T 32004, G98/G99, NBR 16149, NBR 16150, C10/11, RD1669, UNE206006, UNE206007, EN50438

Note: \*1. According to C10/C11, Max. AC Power = Rated AC Power

2. The above parameters might be slightly modified according to different grid codes.
3. If you need more information about our product certifications, please contact our sales.

## R6-20K-T3-32-LV, R6-25K/30K-T4-32-LV

Model	R6-20K-T3-32-LV	R6-25K-T4-32-LV	R6-30K-T4-32-LV
<b>Input (DC)</b>			
Max. PV Array Power [Wp]@STC	30000	37500	45000
Max. Input Voltage [V]	1100		
MPP Voltage Range [V]	180-1000		
Nominal Input Voltage [V]	370		
Startup Voltage [V]	200		
Max. Input Current [A]	32/32/32	32/32/32/32	
Number of MPP Trackers	3	4	
Number of Strings per MPP Tracker	2/2/2	2/2/2/2	
<b>Output (AC)</b>			
Rated AC Output Power [W]	20000	25000	30000
Max. Apparent Power [VA] *1	22000	27500	30000
Rated AC Output Current [A]@230Vac	52.5	65.6	78.7
Max. AC Output Current [A]	57.7	72.2	78.7
Nominal AC Voltage/ Range [V]	127V(F-N)/220V(F-F); 101.6-139.7(F-N)		
Nominal AC Grid Frequency/ Range [Hz]	50, 60 / 44-55, 54-65		
Total Distortion Harmonic [THD]	<3%		
Power Factor	0.8 leading ~ 0.8 lagging		
Feed-in Phase/AC Connection Phases	3/3		
<b>Efficiency</b>			
Max. Efficiency	98.8%		
Euro Efficiency	98.5%		
<b>Protection</b>			
DCI Monitoring	Integrated		
GFCI Monitoring	Integrated		
Grid Monitoring	Integrated		
AC Grounding Detection	Integrated		
AC Short-Circuit Protection	Integrated		
DC Insulation Resistance Detection	Integrated		
DC Surge Protection	Type II		
AC Surge Protection	Type III		
Anti-islanding Protection	AFD		

AFCI Protection	Optional	
<b>Interface</b>		
AC Connection	Terminal Block	
DC Connection	MC4	
Display	LED+APP (Bluetooth)	
Communication Port	RS232+RS485 (RJ45)+DRM(RJ45)	
Communication Mode	Wi-Fi/Ethernet//4G	
Load Monitoring	24/7 (Optional)	
<b>General Data</b>		
Topology	Transformerless	
Nighttime Power Consumption [W]	<0.6	
Operating Temperature Range	-40°C ~ +60°C	
Cooling Method	intelligent fan Cooling	
Ambient Humidity	0% ~ 100% non-condensing	
Max. Operating Altitude [m]	4000m (>3000m power derating)	
Noise [dBA]	<50	
Ingress Protection	IP65	
Mounting	Rear Panel	
Dimensions [H*W*D] [mm]	659.4*473*240	
Weight [kg]	35.5	37.5
Warranty [Year]	5 (Standard)/10/15/20/25 (Optional)	
Certifications	IEC/EN62109-1/2, EN61000-6-1/2/3/4, IEC61683, IEC60068-2, IEC62116, IEC61727, PEA/MEA, VDE0126-1-1/A1, CEI 0-21, VDE-AR-N 4105, AS/NZS4777.2, CQC NB/T 32004, G98/G99, NBR 16149, NBR 16150, C10/11, RD1669, UNE206006, UNE206007, EN50438	

Note: \*1. According to C10/C11, Max. AC Power = Rated AC Power

2. The above parameters might be slightly modified according to different grid codes.

3. If you need more information about our product certifications, please contact our sales.

## Chapter 4 Instructions for installation

### 4.1 Safety Instructions



#### DANGER

- Dangerous to life due to potential fire or electricity shock.
- Do not install the inverter near any inflammable or explosive items.
- This inverter will be directly connected with HIGH VOLTAGE power generation device; the installation must be performed by qualified personnel only in compliance with national and local standards and regulations.



#### NOTICE

- This equipment meets the pollution degree II.
- Inappropriate or the harmonized installation environment may jeopardize the life span of the inverter.
- Installation directly exposed under intensive sunlight is not recommended.
- The installation site must be well ventilated.

### 4.2 Pre-installation Check

#### 4.2.1 Check the Package

Although SAJ's inverters have surpassed stringent testing and are checked before they leave the factory, it is uncertain that the inverters may suffer damages during transportation. Please check the package for any obvious signs of damage, and if such evidence is present, do not open the package and contact your dealer as soon as possible

#### 4.2.2 Check the Assembly Parts

Please refer to the packing list inside the package container.

## 4.3 The Determination of the Installation Method and Position

### 4.3.1 Mounting Method

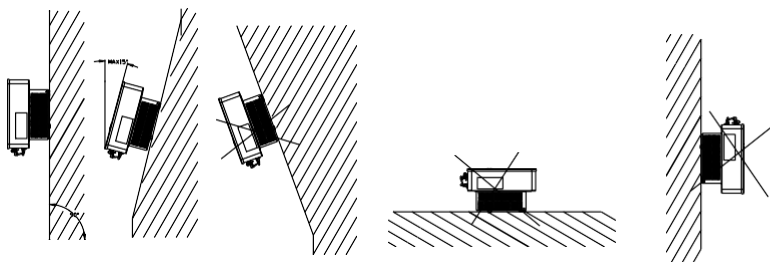

Figure 4.1 Mounting method

- ① The equipment can be installed indoor or outdoor.
- ② Please install the equipment under the guidance of Figure 4.1. Vertical installation on floor level is recommended. Mount vertically or tilted backwards by max. 15°. Never install the inverter tilted forwards, sideways, horizontally or upside down.
- ③ Considering convenience for maintenance, please install the equipment at a position in parallel with line of sight.
- ④ When mounting the inverter, please consider the solidity of wall for inverter, including accessories. Please ensure the Rear Panel tightly.

Before installation, make sure that the wall has enough strength to hold the screws and bear the weight of the equipment. Please make sure the equipment is installed properly.

### 4.3.2 Installation Position

Do not expose the inverter to direct solar irradiation as this could cause power derating due to overheating. The ambient temperature should be between  $-40^{\circ}\text{C} \sim +60^{\circ}\text{C}$  ( $-40^{\circ}\text{F} \sim 140^{\circ}\text{F}$ ) to ensure optimum operation. Choose locations with sufficient air exchange. Ensure additional ventilation, when necessary.

To make sure the installation spot is suitably ventilated, if multiple SAJ on-grid solar inverters are installed same area, the following safety clearance in Figure 4.2 shall be followed for proper ventilation conditions.

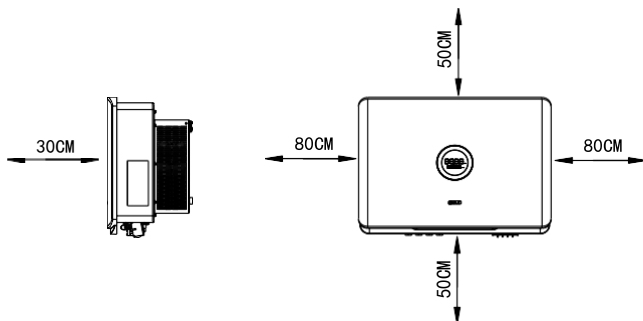

#### 4.2 Installation position

### 4.4 Mounting Procedure

#### 4.4.1 Mark the Positions of the Drill Holes of the Rear Panel

The mounting position should be marked as shown in Figure 4.3, Figure 4.4.

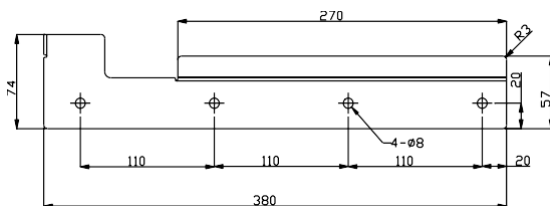

Figure 4.3 Dimensions of rear panel of R6-15K/17K/20K/22K/25K-T2-32

R6-5K/6K/8K/10K/15K-T2-32-LV

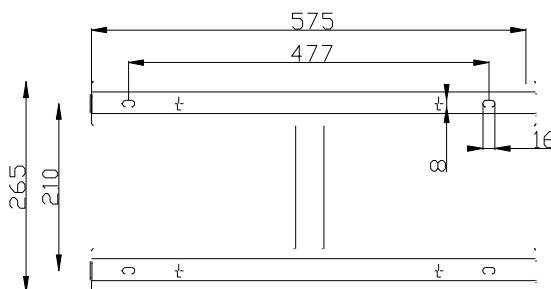

Figure 4.4 Dimensions of rear panel of R6-25K/30K/33K-T3-32, R6-20K-T3-32-LV,  
R6-36K/40K-T4-32, R6-25K/30K-T4-32-LV

#### 4.4.2 Drill Holes and Place the Expansion Tubes

According to the guides, drill 4 holes in the wall (in conformity with position marked in Figure 4.5, Figure 4.6), and then place expansion tubes in the holes using a rubber mallet. According to the position marked in the figure, drill the corresponding holes and adjust the position of the bracket so that the inverter is perpendicular to the horizontal plane.

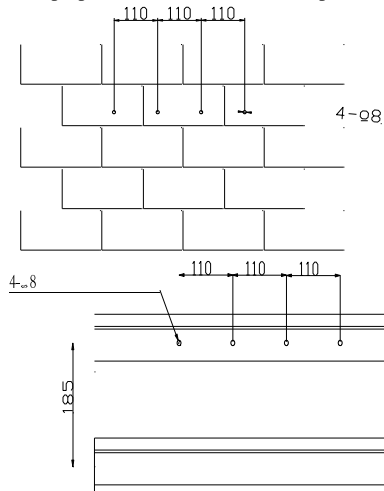

Figure 4.5 Drill holes' dimensions of R6-15K/17K/20K/22K/25K-T2-32

R6-5K/6K/8K/10K/15K-T2-32-LV

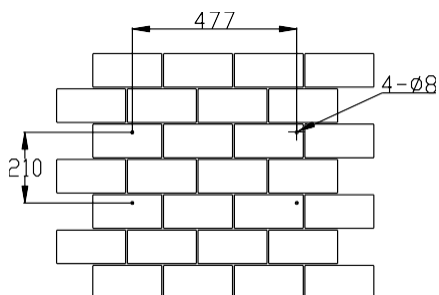

Figure 4.6 Drill holes' dimensions of R6-30K/33K/36K-T3-32, R6-20K-T3-32-LV, R6-40K/50K-T4-32, R6-25K/30K-T4-32-LV

#### 4.4.3 Mount the Screws and the Rear Panel

The panels should be mounted in the mounting position by screws as shown in Figure 4.7.

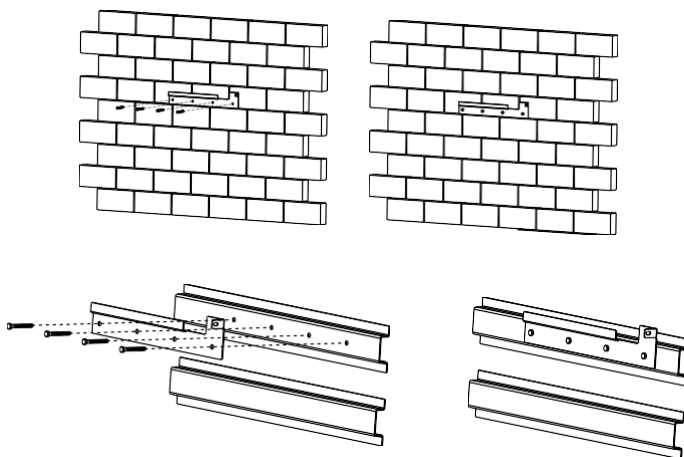

Figure 4.7 Mount the rear panel



#### 4.4.4 Mount the Inverter

Carefully mount the inverter to the rear panel as shown in Figure 4.8 and 4.9, Make sure that the rear part of the equipment is closely mounted to the rear panel.

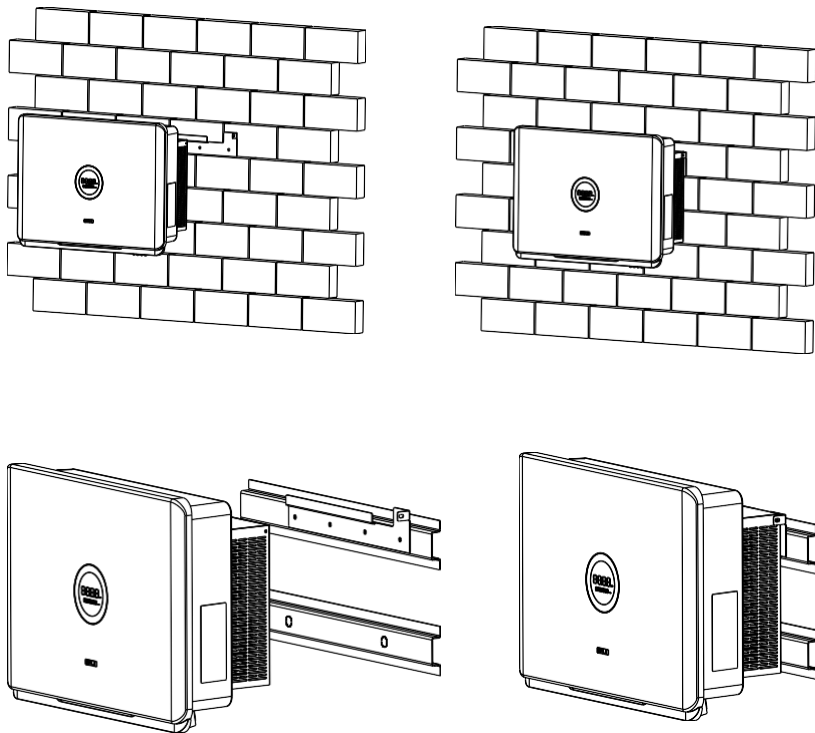

Figure 4.8 Mount inverter

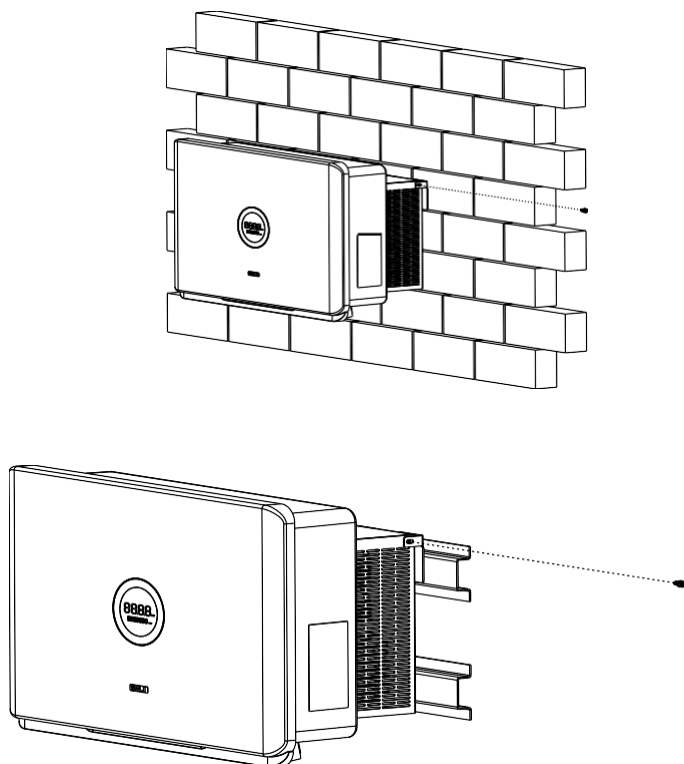

Figure 4.9 Fasten the inverter and hanging panel with screws

## Chapter 5 Electrical Connection

### 5.1 Safety Instruction for Hot-line Job

Electrical connection must only be operated on by professional technicians. Please keep in mind that the inverter is a bi-power supply equipment. Before connection, necessary protective equipment must be employed by technicians, including insulating gloves, insulating shoes and safety helmet.



#### **DANGER**

- Dangerous to life due to potential fire or electricity shock.
- When power -on, the equipment should be in conformity with national rules and regulations.
- The direct connection between the inverter and high voltage power systems must be operated by qualified technicians in accordance with local and national power grid standards and regulations.



#### **WARNING**

- When the PV array is exposed to light, it supplies a DC voltage to the inverter.



#### **NOTICE**

- Electrical connection should in conformity with proper stipulations, such as stipulations for cross-sectional area of conductors, fuse and ground protection.
- The overvoltage category on DC input port is II, on AC output port is III.

## 5.2 Specifications for Electrical Interface

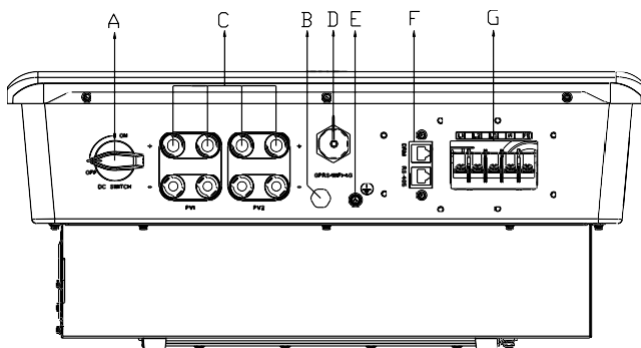

Figure 5.1 Electrical interface of R6-15K/17K/20K/22K/25K-T2-32,  
R6-5K/6K/8K/10K/15K-T2-32-LV

Code	Name
A	DC Switch
B	Decompression Valves
C	DC Input
D	RS232 Communication (GPRS/ Wi-Fi /4G)
E	Ground Connection
F	RS485 Communication
G	Terminal Block

Table 5.1 Specifications for interface

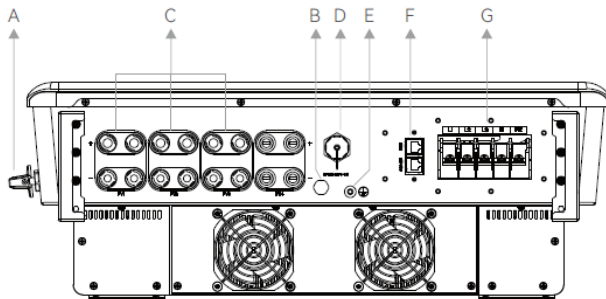

Figure 5.2 Electrical interface of R6-25K/30K/33K/36K-T3-32, R6-20K-T3-32-LV

Code	Name
A	DC Switch
B	Decompression Valves
C	DC Input
D	RS232 Communication (GPRS/ Wi-Fi /4G)
E	Ground Connection
F	RS485 Communication
G	Terminal Block

Table 5.2 Specifications for interface

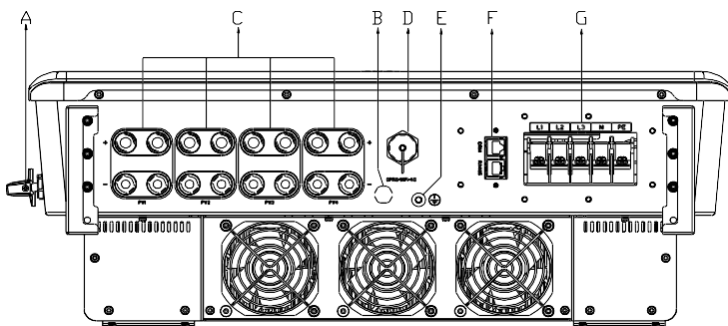

Figure 5.2 Electrical interface of R6-40K/50K-T4-32, R6-25K/30K-T4-32-LV

Code	Name
A	DC Switch
B	Decompression Valves
C	DC Input
D	RS232 Communication (GPRS/ Wi-Fi /4G)
E	Ground Connection
F	RS485 Communication
G	Terminal Block

Table 5.3 Specifications for interface

## 5.3 AC Connection

Type	Cross-sectional area of cables (mm <sup>2</sup> )	
	Scope	Recommended value
R6-15K/17K/20K/22K/25K-T 2-32 R6-5K/6K/8K/10K/15K-T2-32 -LV	10.0-16.0	16.0
R6-25K/30K/33K/36K-T3-32 R6-20K-T3-32-LV	16.0-35.0	25.0
R6-40K/50K-T4-32 R6-25K/30K-T4-32-LV	16.0-35.0	25.0

Table 5.4 Recommended power grid connecting cable specification

If the grid-connection distance is too far, please select AC cable with larger diameter as per the actual condition.

### 5.3.1 R6-15~50K-T2-T3-T4-32, R6-5~30K-T2-T3-T4-32-LV AC side electrical connection

1. Ground of the inverter. After penetrating the external hex head screw through OT terminal of the grounding line, screw in the grounding port of enclosure of the inverter in clockwise direction and make sure it's screwed up tightly.

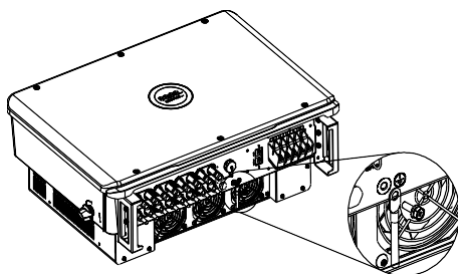

Figure 5.4 Inverter ground protection

2. Screw off the screws at the AC output wire cover and take out the cover. Penetrate the AC cable of which the insulation layers has been peeled off through the AC waterproof locking screw hole of the cover. Lock L1 wire, L2 wire, L3 wire, N wire and PE wire tightly as per the marked connection positions on the interface board.

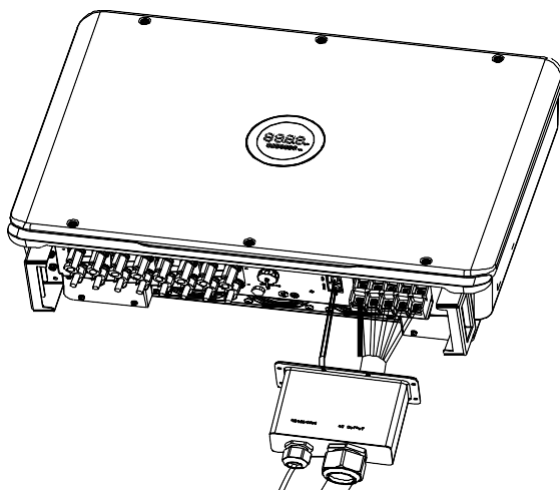

Figure 5.5 Connect cable

3. After fixing the cover at the AC output wire terminal with screws, tighten up the AC waterproof nut.

## 5.4 DC Side Connection

Cross-sectional area of cables (mm <sup>2</sup> )		Outside diameter of the cables (mm)
Scope	Recommended value	
4.0-6.0	4.0	4.2-5.3

Table 5.5 Recommended specifications of DC cables

DC connector is made up of the positive connector and the negative connector

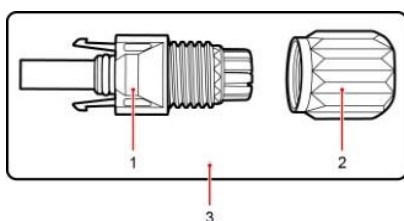

Figure 5.6 Positive connector

1. Insulated enclosure 2. Lock screw 3. Positive connector

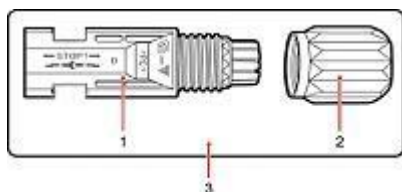

Figure 5.7 Negative connector

1. Insulated enclosure 2. Lock screw 3. Negative connector



### NOTICE

· Please place the connector separately after unpacking in order to avoid confusion for connection of cables.



Please connect the positive connector to the positive side of the solar panels, and connect the negative connector to the negative side of the solar side. Be sure to connect them in right position.

### Connecting Procedures:

1. Tighten the lock screws on positive and negative connector.
2. Use specified strip tool to strip the insulated enclosure of the positive and negative cables with appropriate length.

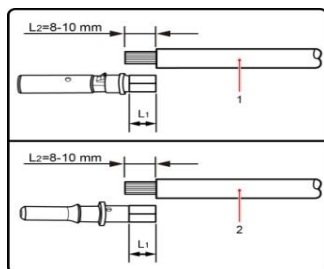

1. Positive cable

2. Negative cable

Figure 5.8 Connecting cables

3. Feed the positive and negative cables into corresponding lock screws.
4. Insert the positive and negative connectors into positive cable and negative cable whose insulated enclosure has been stripped off, and crimp them tightly with a wire crimper. Make sure that the withdrawal force of the pressed cable is bigger than 400N.
5. Plug in the pressed positive and negative cables into relevant insulated enclosure, a “click” should be heard or felt when the contact cable assembly is seated correctly.
6. Fasten the lock screws on positive and negative connectors into respective insulated enclosure and make them tight.
7. Connect the positive and negative connectors into positive and negative DC input terminals of the inverter, a “click” should be heard or felt when the contact cable assembly is seated correctly.

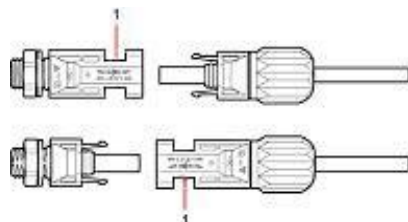

1. Connection port

Figure 5.9 Connect the inverter

### ! NOTICE

- Before inserting the connector into DC input terminal of the inverter, please make sure that the DC switch of the inverter is OFF.
- Please use the original terminal to install.

## 5.5 Communication Connection

R6 inverter is standardly equipped with a RS485 interface and a RS232 interface.

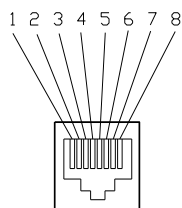

Figure 5.10 RS485 pin

Pin Number	Description	Function
1	NC	
2	GND_W	Ground wire

3	+7V_W	Power supply
4	NC	
5	NC	
6	NC	
7	RS485-A	Transmission RS485 differential signal
8	RS485-B	

Table 5.6 RS485 pin port definition

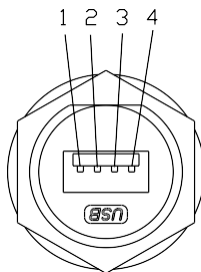

Figure 5.11 RS232 pin

Pin Number	Description	Function
1	+7V	Power supply
2	RS-232 TX	Send data
3	RS-232 RX	Receive data
4	GND	Ground wire

Table 5.7 USB pin port definition

1. USB interface could be externally connected with eSolar AIO3 module, for operation in details please refer to eSolar AIO3 module Quick Installation Guide in

<https://www.saj-electric.com/>.

2. USB interface could be externally connected with eSolar 4G module, for operation in details please refer to eSolar 4G module Quick Installation Guide in <https://www.saj-electric.com/>.

3. USB interface could be externally connected with eSolar WiFi module, for operation in details please refer to eSolar WiFi module Quick Installation Guide in <https://www.saj-electric.com/>.

## Chapter 6 Debugging Instructions

### 6.1 Introduction of HMI (Human-Machine Interface)

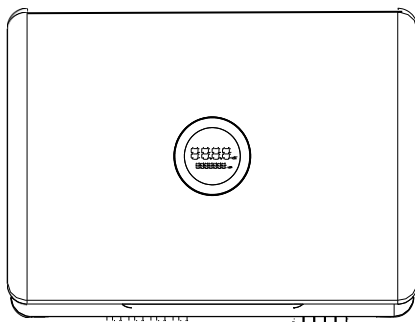

Figure 6.1 Human-Machine Interface

Display	Status		Description
Ring Light	Green	Solid green	The inverter is in normal on-grid state
	Green	Breathing Mode	The inverter is in the initialization or waiting state.
	Red	Solid red	An error occurs
	Red	Breathing Mode	Software is upgrading in the inverter.
	OFF		Power off
LED Panel 1	8888. / E036		Current output power (kW)
LED Panel 2	888888 kWh		Total energy (kWh)

Table 6.1 Interface description

## **6.2 Monitoring Operation**

- R6 series products and they could be monitored through eSolar APP.
- This equipment is standardly equipped with a USB interface which could transfer AIO3/4G module (with built-in Bluetooth) and Wi-Fi module to monitor running state of the equipment.

### **6.2.1 APP introduction**

eSolar could achieve communication with the equipment via Bluetooth, 4G and Wi-Fi and it is an APP for nearby and remote monitoring.

Download APP

Installers using iOS system could search for “eSolar O&M” in App Store and download this App.

Installers using Android system could search for “eSolar O&M” in Google play and download this App.

For iOS/Android system, Installers could visit SAJ official website: [www.saj-electric.cn](http://www.saj-electric.cn) and scan the QR code to download “eSolar O&M” APP.

Account---Please use the installer account to login.

Note: For the end user, please download and install the “eSolar Air” APP and log in to the APP or SAJ official website to register your account.

### **6.2.2 Nearby monitoring**

Connecting way — Bluetooth connection

After installing the eSolar AIO3/4G/WiFi module (with built-in Bluetooth) the mobile phone could be directly connected with the inverter via Bluetooth.

## Connection setting

1. Log in eSolar O&M APP.	2. Choose "User" interface → choose "Remote control".	3. Choose connection way as "Bluetooth" → choose "next step".
		<p>Way of connection</p> <p>Please choose ways of connection</p> <p>Bluetooth WIFI Cloud</p> <p>Tips:  (1)Please turn on the inverter and mobile phone bluetooth;  (2)Determine the connection of the communication module;</p> <p>NEXT STEP</p>
4. Search for equipment → click the Bluetooth name matched with the inverter.	5. Select the configuration method of the module network connection.	6. Connect successfully → set country and grid code for first start-up → after inverter start, users can view inverter's information.

## Equipment information

Connection way, running state, basic information, running information, Power information and events information of the communication of the inverter could be checked.

### 1. Click “Basic info”

Inverter model, Module SN code, Module firmware version, Communication board firmware version, Main board firmware version, Slave board firmware version could be checked.

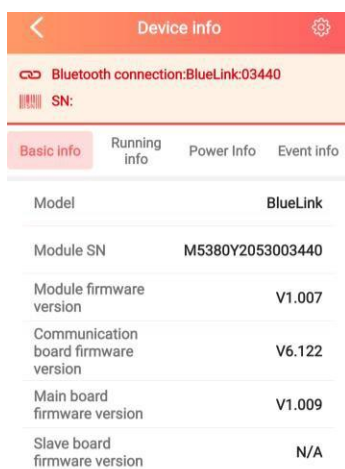

The screenshot shows a mobile application interface for 'Device info'. At the top, there is a red header with a back arrow, the title 'Device info', and a settings gear icon. Below the header, there is a status bar indicating 'Bluetooth connection:BlueLink:03440' and a QR code icon next to 'SN:'. A horizontal menu below the status bar has four tabs: 'Basic info' (selected), 'Running info', 'Power Info', and 'Event info'. The main content area displays a table with the following information:

Model	BlueLink
Module SN	M5380Y2053003440
Module firmware version	V1.007
Communication board firmware version	V6.122
Main board firmware version	V1.009
Slave board firmware version	N/A

Fig. 6.2 Basic information

### 2. Click “Running info”

PV information (voltage and current at PV terminal), Grid power information (voltage, current and frequency at AC terminal), etc.



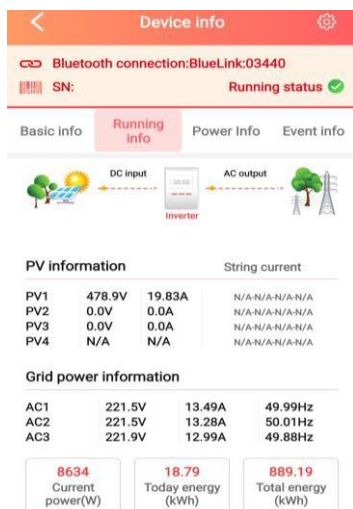
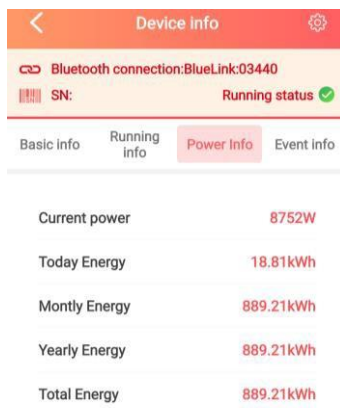

Fig. 6.3 Running information

## 3. Click “Power info”

Current power, today energy, monthly energy, yearly energy, total energy could be checked.



Update time: 2021-08-26 11:30:15

Fig. 6.4 Power information

#### 4. Click “Event info”

Time of the events, events sequence number (referring to fault codes details in Chapter 7 Fault Codes and Common Troubleshooting) and events content of the faults of the inverter could be checked.

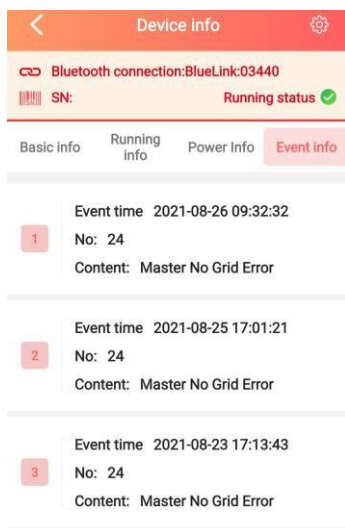

Fig. 6.5 Events information

**6.2.3 Remote monitoring**

1. Connect the internet via the eSolar AIO3 module and upload the inverter data onto the server and customers could monitor running information of the inverter remotely via the eSolar Web Portal or their mobile customer terminals.
2. Connect the internet via the eSolar 4G module and upload the inverter data onto the server and customers could monitor running information of the inverter remotely via the eSolar Web Portal or their mobile customer terminals.
3. Connect the internet via the eSolar WiFi module and upload the inverter data onto the server and customers could monitor running information of the inverter remotely via the eSolar Web Portal or their mobile customer terminals.

## Chapter 7 Fault Code and Troubleshooting

Error Code	Explanation
01	Master Relay Error
02	Master EEPROM Error
03	Master Temperature High Error
04	Master Temperature Low Error
05	Master Lost Communication
06	Master GFCI Device Error
07	Master DCI Device Error
08	Master Current Sensor Error
09/11/13	Master Phase1/ Phase2/ Phase3 Voltage High
10/12/14	Master Phase1/ Phase2/ Phase3 Voltage Low
15	Master Voltage 10Mins High
18	Master Grid Frequency High
19	Master Grid Frequency Low
24	Master No Grid Error
27	Master GFCI Error
28/29/30	Master Phase1/ Phase2/ Phase3 DCI Error
31	Master ISO Error
32	Master Bus Voltage Balance Error
33	Master Bus Voltage High
34	Master Bus Voltage Low
35	Master Grid Phase Error
36	Master PV Voltage High Error
37	Master Islanding Error
38	Master HW Bus Voltage High
39	Master HW PV Current High
41	Master HW Inv Current High

44	Master Grid NE Voltage Error
45/46/47/48	Master Fan1/Fan2/Fan3/Fan4 Error
49	Lost Communication between DSP and PowerMeter
81	Lost Communication
83	Master Arc Device Error
84	<b>Master PV Input Error</b>
85	Authority expires
86	Master DRM0 Error
87	Master Arc Error

Table 7.1 Error Code

General troubleshooting methods for inverter are as follows:

<b>Fault Information</b>	<b>Troubleshooting</b>
Relay Error	If this error occurs frequently, please contact your distributor or call SAJ technical support.
Storer Error	If this error occurs frequently, please contact your distributor or call SAJ technical support.
High Temperature Error	Check whether the radiator is blocked, whether the inverter is in too high or too low temperature, if the above mentioned is in normal, please contact your distributor or call SAJ technical support.
Master Lost Communication	If this error occurs frequently, please contact your distributor or call SAJ technical support.
GFCI Devices Error	If this error occurs frequently, please contact your distributor or call SAJ technical support.
DCI Devices Error	If this error occurs frequently, please contact your distributor or call SAJ technical support.
Current Sensor Error	If this error occurs frequently, please contact your distributor or call SAJ technical support.

AC Voltage Error	<ul style="list-style-type: none"><li>·Check the volt . of the grid</li><li>·Check the connection between the inverter and the grid.</li><li>·Check the settings of the on -grid standards of the inverter.</li><li>·If the volt . of the grid is higher than the volt. regulated by local grid, please inquire the local grid workers whether they can adjust the volt. at the feed point or change the value of the regulated volt.</li><li>·If the volt . of the grid is in regulated range as allowed and LCD still in this error, please contact your distributor or call</li></ul>
------------------	--

Fault Information	Troubleshooting
	SAJ technical support.
Frequency Error	Check the setting of country and check the frequency of the local grid. If the above mentioned are in normal, please contact your distributor or call SAJ technical support.
Grid Lost Error	Check the connection status between the AC side of the inverter and the grid, if the above mentioned are in normal, please contact your distributor or call SAJ technical support.
GFCI Error	Check the insulation resistance of the positive side and negative side of the solar panel; check whether the inverter is in wet environment; check the grounding of the inverter. If the above mentioned are in normal, please contact your distributor or call SAJ technical support.
DCI Error	If this error exists always, please contact your distributor or call SAJ technical support.
ISO Error	Check the insulation resistance of the positive side and negative side of the solar panel; check whether the inverter is in wet environment; check whether the grounding of the inverter is loose or not. If the above mentioned are in normal, please contact your distributor or call SAJ technical support.
Overcurrent	Check the connection status between the inverter and the grid and test whether the volt. of the grid is stable or not, if the above mentioned are in normal, please contact your distributor or call SAJ technical support.
Over Bus Voltage	Check the settings of the solar panel. SAJ designer can help you. If the above mentioned are in normal, please contact your distributor or call SAJ technical support.
PV Overcurrent	If this error always exists, please contact your distributor or call SAJ technical support.
PV Voltage Fault	Check the settings of the solar panel. SAJ designer can help you. If the above mentioned are in normal, please contact your distributor or call SAJ technical support.
Lost Communication	Check the connection of communication cables between control board and display board. If the above mentioned are in normal, please contact your distributor or call SAJ technical support.

<b>Fault Information</b>	<b>Troubleshooting</b>
Null line-to-earth voltage fault	Check if connection of the AC output grounding terminal is stable and reliable. If the content mentioned as above is normal, please contact your distributor or call SAJ technical support.

Table 7.2 Troubleshooting



## **Chapter 8 Recycling and Disposal**

This device should not be disposed as residential waste. An inverter that has reached the end of its life and is not required to be returned to your dealer and it must be disposed carefully by an approved collection and recycling facility in your area.

## Chapter 9 Contact SAJ

### **Guangzhou Sanjing Electric Co., Ltd.**

SAJ Innovation Park, No.9, Lizhishan Road, Guangzhou Science City, Guangdong, P.R.China.

Web: <http://www.saj-electric.com>

### **Technical Support & Service**

Tel:+86 20 6660 8588

Fax:+86 20 6660 8589

E-mail: [service@saj-electric.com](mailto:service@saj-electric.com)

### **International Sales**

Tel: +86 20 6660 8618/6660 8619/6660 0082/6660 0086

Fax: +86 20 6660 8589

E-mail:[info@saj-electric.com](mailto:info@saj-electric.com)

### **Domestic Sales**

Tel: +20 6660 0058/6660 0082

Fax: +20 6660 8589

# SAJ Warranty Policy

## 1.1 Standard Warranty Period

Starting from the date of shipment from SAJ factory or 60 months (5 years) starting from the date of purchased invoice marked (whichever is longer).

## 1.2 Extension of Warranty

The purchaser of SAJ inverters should extend the warranty period in 18 months from the date of settlement or 30 months from the date of shipment from SAJ by providing the serial number of the unit and purchased receipt (whichever is shorter). You can purchase the warranty extension for 10 years, 15 years, 20 years or 25 years but do not apply the extension beyond the specified date, or else your application will be unacceptable. Please refer to the Warranty Extension Order Form for more details.

Once the purchase of the warranty extension goes into effect, SAJ will send the warranty extension certificate to the customer for confirming the extended warranty period.

## 1.3 Warranty Conditions

If your inverter gets fault and requires troubleshooting, please contact your distributor or dealer directly. Alternatively, feedback briefly to SAJ service hotline for logging and send your warranty card to our service department by fax/email to process the warranty claim.

During the Warranty Period, SAJ covers all costs for replacing any product or parts of the product proved to be defective in design or manufacture. To claim the warranty under the warranty policy of SAJ, you need to supply us with the following information and documentation regarding the faulty inverter:

1. Product Model No.(e.g. R6-40K-T4-32) and serial number (e.g.M5380Y2053003440).
2. Copy of the invoice and warranty certificate of the inverter.
3. Copy of the installation report and installation date.

4. Error message on eSolar Portal (if available ) or any information which would be helpful to determine the defect.

5. Detailed information about the entire system (battery, circuits, etc.).

#### **1.4 After receiving above information, SAJ will decide how to proceed the service**

- Repaired by SAJ factory, or SAJ authorized service center overhaul.
- Repaired on-site by SAJ Service Center.
- Offer a replacement device of equivalent value according to model.

In the case of an exchange, the remaining portion of the original warranty period will be transferred to the replacement device. You will not receive a new certificate, as your entitlement is documented at SAJ.

If the inverter needs to be replaced following assessment, SAJ will send a replacement unit immediately. The defective inverter should be sent back to the closest SAJ Service Center by packing in its original package if possible.

#### **1.5 Service after Warranty Expiration**

If the inverters for maintenance are out of warranty, SAJ charges an on-site service fee, parts, labor cost and logistic fee to end-user. Detailed standard refers to the listed table.

<b>Item</b>	<b>Return Factory Maintenance</b>	<b>On-site Maintenance</b>
Without parts replacement	Labor + Logistic fee (to & from SAJ)	Labor + On-site attendance fee
With parts replacement	Labor + Parts + logistic fee (to & from SAJ)	Labor + On-site attendance fee + Parts

- On-site attendance fee: Cost of travel and time for the technician in attending on-site.
- Parts: Cost of replacement parts (including any shipping/admin fee that may apply).
- Labor: Labor time fee charged for the technician, who is repairing, maintaining, installing (hardware or software) and debugging the faulty product.

■ Logistic fee: Cost of delivery, tariff and other derived expense when defective products are sent from user to SAJ or/and repaired products are sent from SAJ to user.

### **1.6 Exclusion of Liability**

Any defect caused by the following circumstances will not be covered by the manufacturer's warranty (the Dealers or Distributors are responsible and authorized by SAJ for the following investigation):

- ◆ "Warranty Card" not being sent back to Distributor/Dealer or SAJ;
- ◆ Product modified, parts replaced or attempt to maintain;
- ◆ Changes, or attempted repairs and erasing of series number or seals by non SAJ technician;
- ◆ Incorrect installation or commissioning;
- ◆ Failure to comply with the safety regulations (VDE standards, etc.);
- ◆ The inverter has been improperly stored and damaged while being stored by the Dealer or the end user;
- ◆ Transport damage (including scratch caused by movement inside packaging during shipping). A Claim should be made directly to shipping company/insurance Company as soon as the container/package is unloaded and such damage is identified;
- ◆ Failure to follow any / all of the user manual, the installation guide and the maintenance regulations;
- ◆ Improper use or misuse of the inverter;
- ◆ Insufficient ventilation of the inverter;
- ◆ Influence of foreign objects and force majeure (lightning, grid overvoltage, severe weather, fire, etc.)

## Warranty Card

The installer should fill in the second form while installing the inverter. For warranty claim, please complete the below forms and send this page to SAJ attached with the Customer's invoice.

**For customer to fill in**

Name:		
City:	Country:	Zip:
Tel:	Fax:	E-mail:

**Information on device**

Device type:	Serial No.(S/N):
Invoice No:	Commissioning date:
Fault time:	
Error message (Display reading):	
Brief fault description & photo:	
Signature: _____ Date: _____	



**For installer to fill in**

Modules used:		
Modules per string:	No. of string:	
Installation company:	Contractor license number:	
Company:		
City:	Country:	Zip:
Tel:	Fax:	E-mail:
Signature: _____ Date: _____		





## **Guangzhou Sanjing Electric CO., LTD.**

ADD: SAJ Innovation Park, No.9, Lizhishan Road, Science City,  
Guangzhou High-tech Zone, Guangdong, P.R.China (Zip: 510663)

Tel: +86 20 6660 8588      Fax: +86 20 6660 8589

Web: <http://www.saj-electric.com>