

## CHS2 Inverter Quick Installation Guide

The installation of this device must be operated by safety certified professionals, see the user manual for detailed information.

### 1. Installation Method and Position

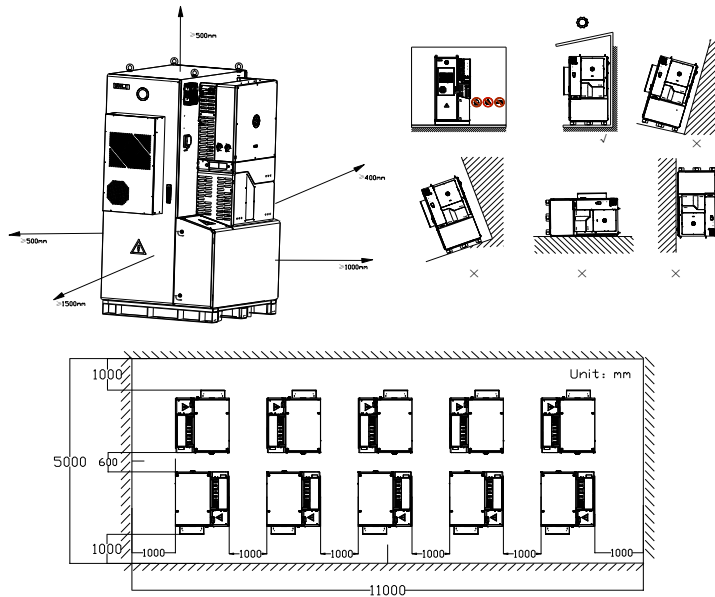

### 2. Installing the Inverter

#### Ground Mounting 1

1. Place the cardboard flat on the floor, mark the location of the holes with a marker, then remove the cardboard. Drill the holes by using an electric drill (18mm in diameter, 80-90mm in depth). Disassemble the M12\*80 expansion screws and put the screws sleeves into the holes.

**Note:** The ground should be flat and no inclination.

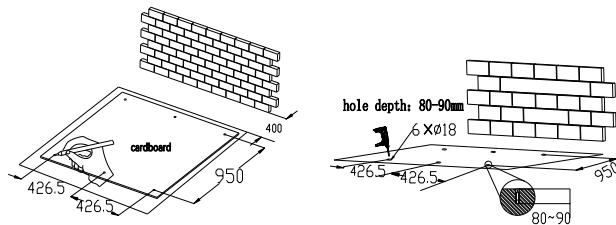

#### 2. Install the cabinet to the designated location

By using a crane:

As shown in the following figure, lift the cabinet, align the holes at the cabinet bottom with the drilled holes, and place it onto the floor. A force greater than 2t is required to move this device, the height between the sling and the top surface must be greater than or equal to 1.5 meter.

By using a forklift:

As shown in the following figure, move the cabinet, align the holes at the cabinet bottom with the drilled holes, and place it onto the floor.

To choose a right forklift, refer to the following requirements:

- Load capacity must be greater than 2 tons.
- The length of the metal forks must be greater than 1.2 meter. Use fork extensions if needed.
- The forks can slide under the cabinet bottom without damaging the cabinet.

To use the forklift, make sure that:

- The forks should be extend out of the cabinet.
- Adjust the distance between the two forks to ensure load stability.

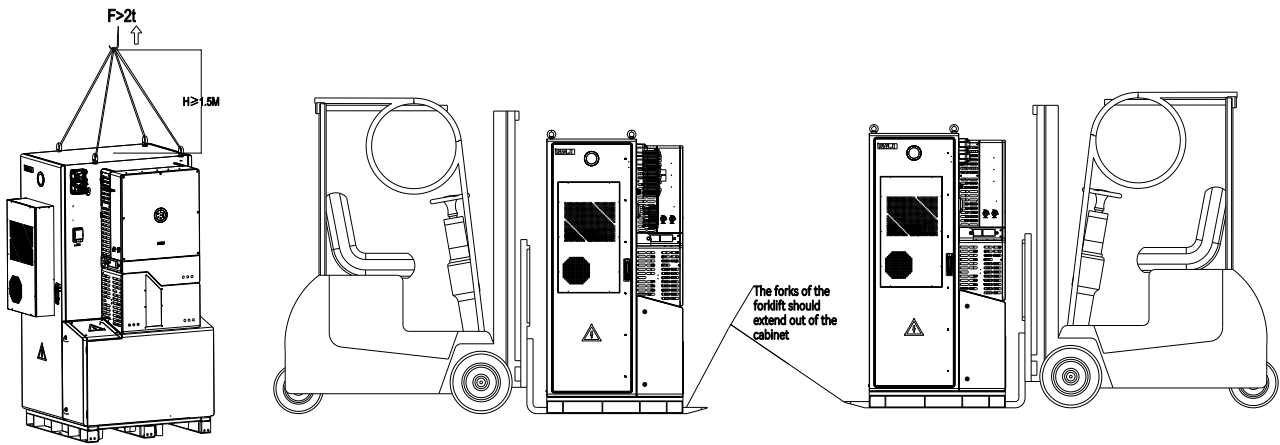

3. Install the M12\*80 screw bolt at the bottom of the cabinet and secure them by using a wrench.

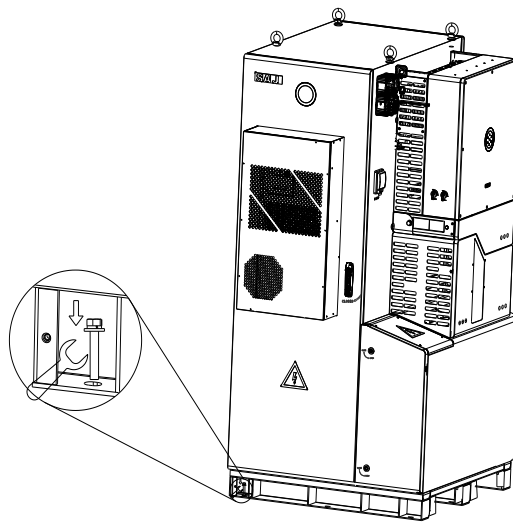

## Ground Mounting 2

1. Same as 2 in ground mounting 1, place the machine stably on the ground.
2. Take out the accessories as shown in the picture, mark the four corners of the cabinet, and then drill holes according to the marked positions with a depth of 80 - 90mm.

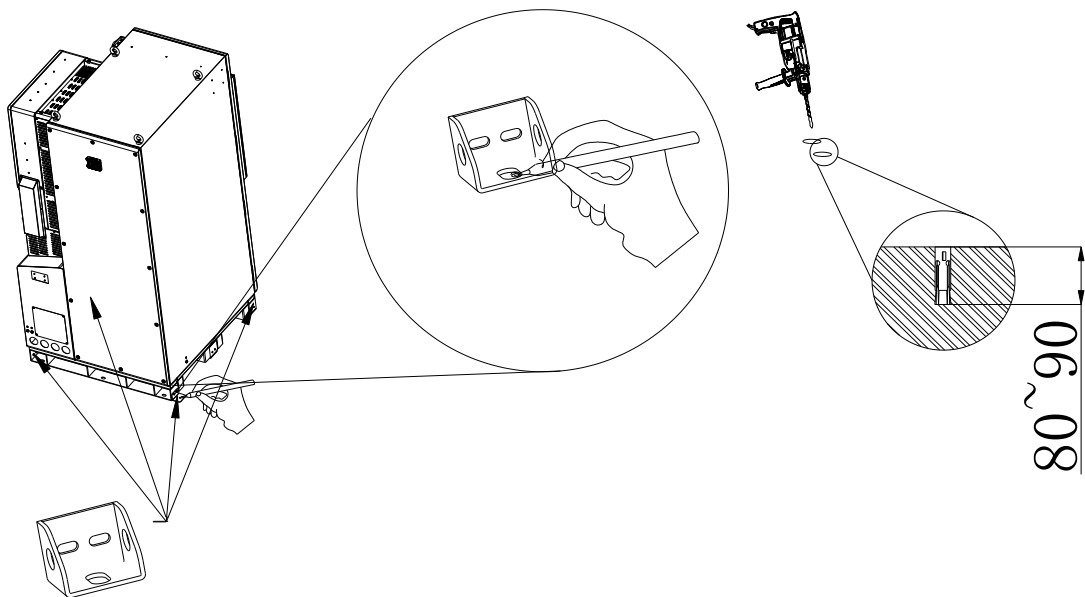

- Find 4 mounting brackets as shown in the picture among the accessories, and install them on the 4 corners of the cabinet respectively.

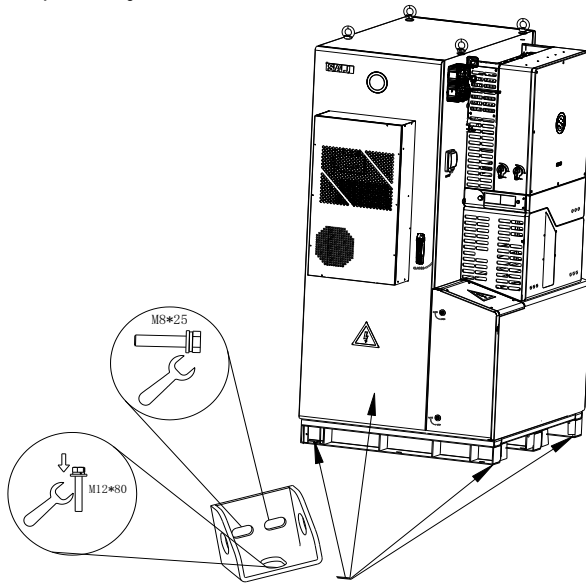

### □ 3. Grounding Connection

**Note:** A 6 mm<sup>2</sup> conductor cross-sectional area of cable is recommended for additional grounding cable.

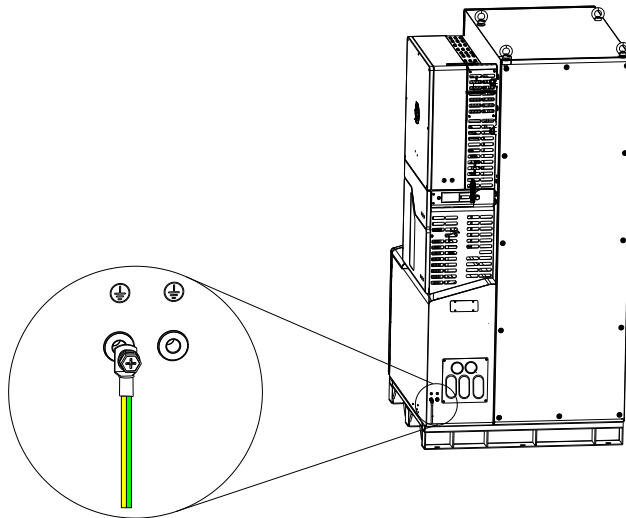

### □ 4. Preparation Before Installation

**Note:** When the machine is wired to the outside, these cables need to pass through the hole in the lower right corner of the machine.

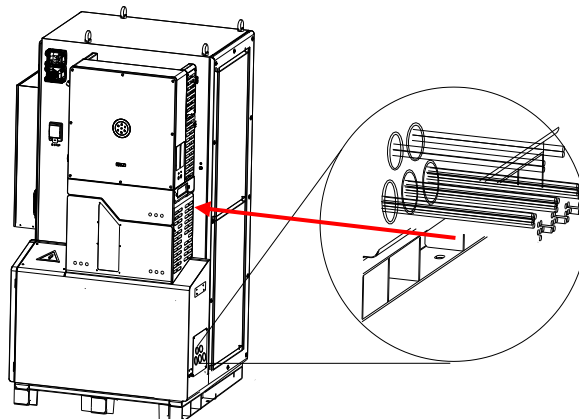

1. Disassemble the metal plate at the outlet to facilitate wiring operations.
2. Use a knife to cut the end of the cable sleeve at the cable hole.
3. Remove the decorative panel of the inverter.
4. Remove the AC cover.
5. Loosen the beam suspended in the middle of the inverter.
6. Remove the baffle under the inverter.

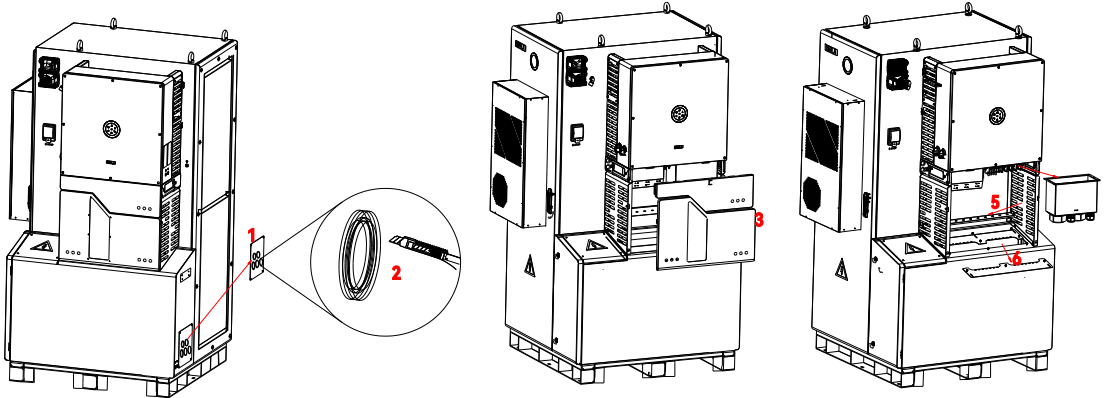

## 5. Connecting the AC Cable

Recommended specifications of GRID cables:

Type	Cable cross-sectional area (mm <sup>2</sup> )		Conductor material
	Range	Recommend	
CHS2-(29.9K-50K)-(T4, T6)-X	35 - 70	50	Copper
Grounding cable cross-sectional area (mm <sup>2</sup> ): 25			

Recommended specifications of GEN and Back-up cables:

Type	Cable cross-sectional area (mm <sup>2</sup> )		Conductor material
	Range	Recommend	
CHS2-(29.9K-50K)-(T4, T6)-X	16 - 25	25	Copper
Grounding cable cross-sectional area (mm <sup>2</sup> ): 25			

Note: If the grid-connection distance is too far, please select an AC cable with larger diameter as per the actual condition.

1. Pass the cables to be connected through the corresponding waterproof holes.

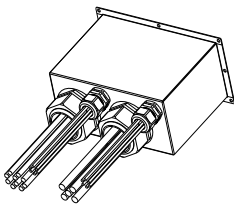

2. Fix the inner core wires of the GRID, GEN, and backup cables to the terminals marked L1, L2, L3, N, and PE on the machine.

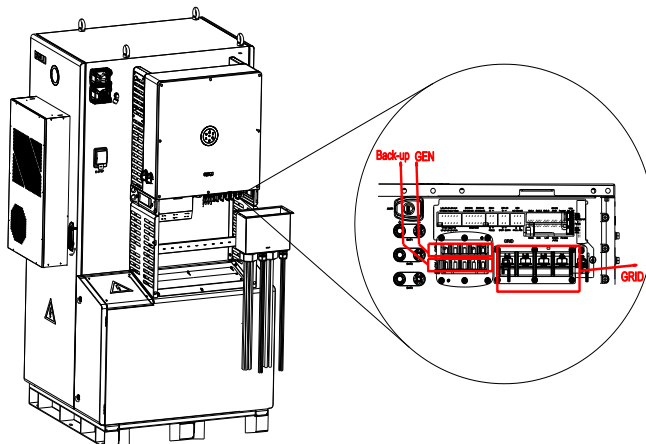

## 6. PV Side Connection

Recommended specifications of DC cable

Conductor cross-sectional area of cables (mm <sup>2</sup> )		Conductor material
Scope	Recommended value	
4.0 - 6.0	4.0	Outdoor multi-core copper wire cable, complying with 1000 V DC

**Note:** When the inverters are used in parallel, it is necessary to ensure that the PV power of all inverters is consistent as much as possible.

1. Remove the upper cover of the PV cover.

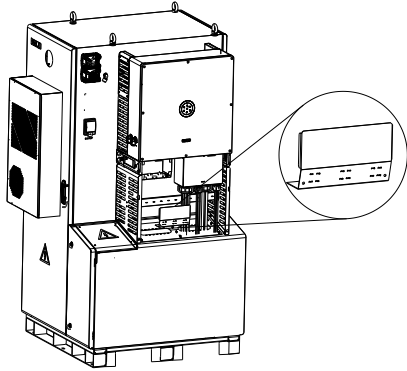

2. Loosen the lock screws on positive and negative connector.
3. Use a 3-mm wide-bladed screwdriver to strip the insulation layer around 8 to 10 mm length from one end of each cable.

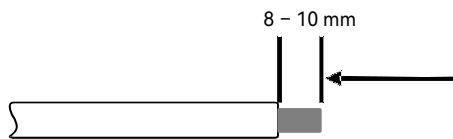

4. Insert the cable ends to the sleeves. Use a crimping plier to assembly the cable ends.

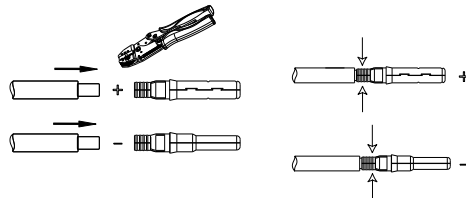

5. Insert the assembled cable ends into the positive and negative connectors. Gently pull the cables backwards to ensure firm connection.

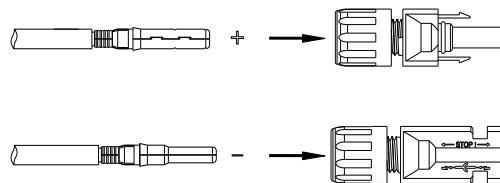

6. Tighten the lock screws on the positive and negative cable connectors.

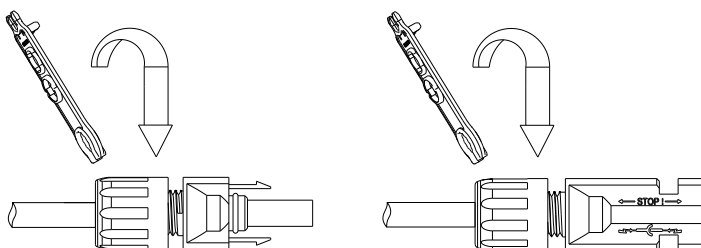

- Make sure the DC switch is at OFF position. For further safety consideration, it is suggested that a reliable tool (such as a lock with a key) be used to lock the switch and make sure that others cannot unlock it easily.

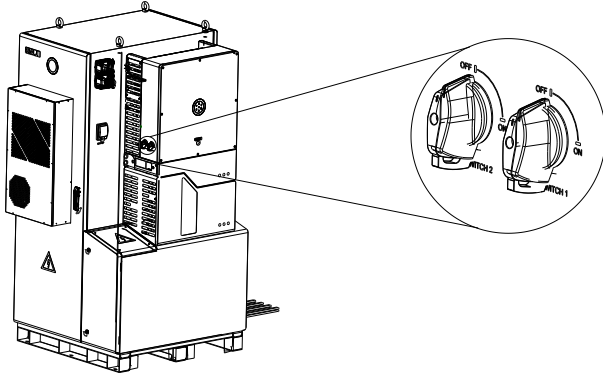

- Insert the positive and negative cable connectors into the positive and negative PV ports on the inverter until you hear a “click” sound to ensure firm connection.

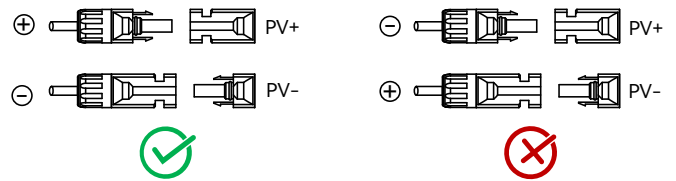
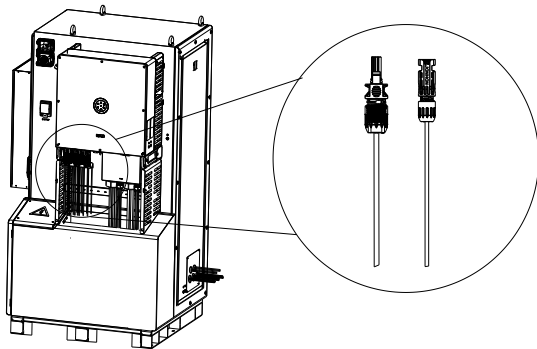

- Install the PV cover on the PV port, secure it with screws.

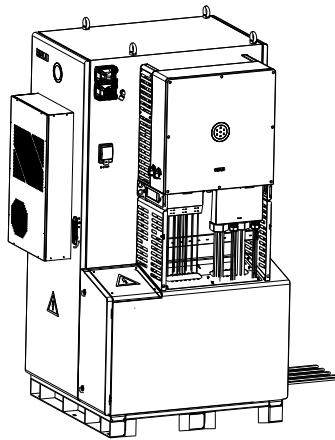

## 7. Communication Connection

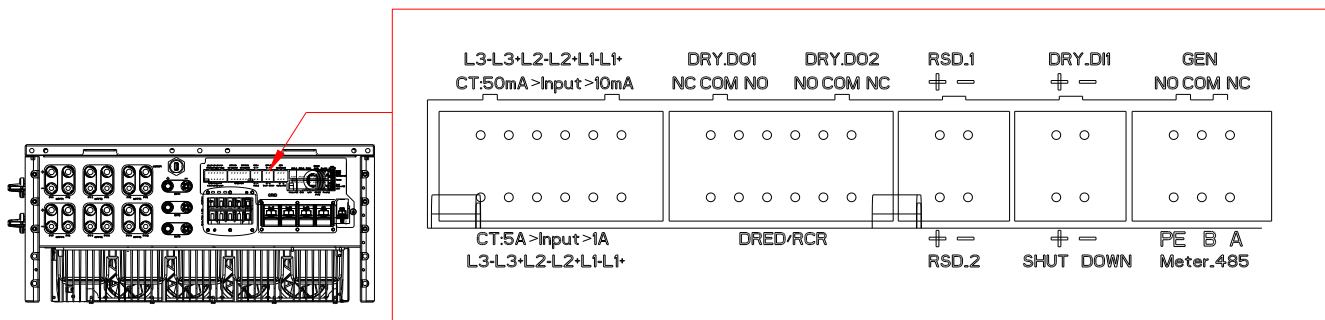

- Export Limit Setting

The meter communication cable can be connected to the Meter\_485 of the Phoenix terminal of the inverter and the METER interface of the RS485.

**Note:** The electric meter needs to be CHINT’s DTSU666 electric meter.

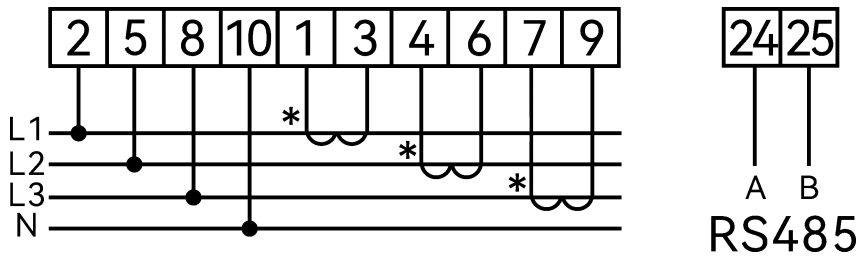
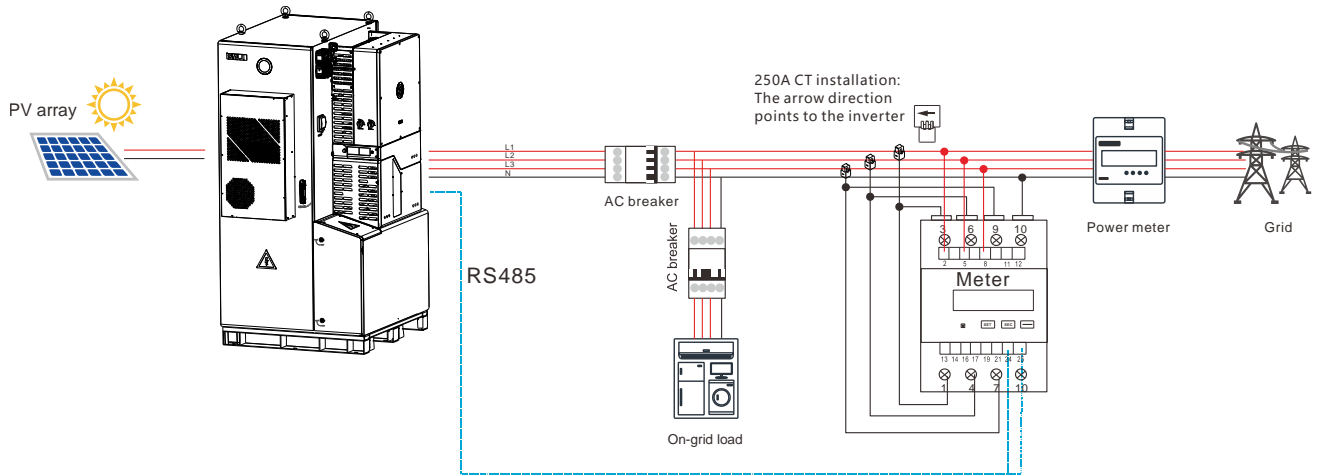

If two meters are used, set the address of the inverter-side meter to 2. Do NOT change the default address 1 of the grid-side meter.

The CT arrow direction points to the CHS2 inverter.

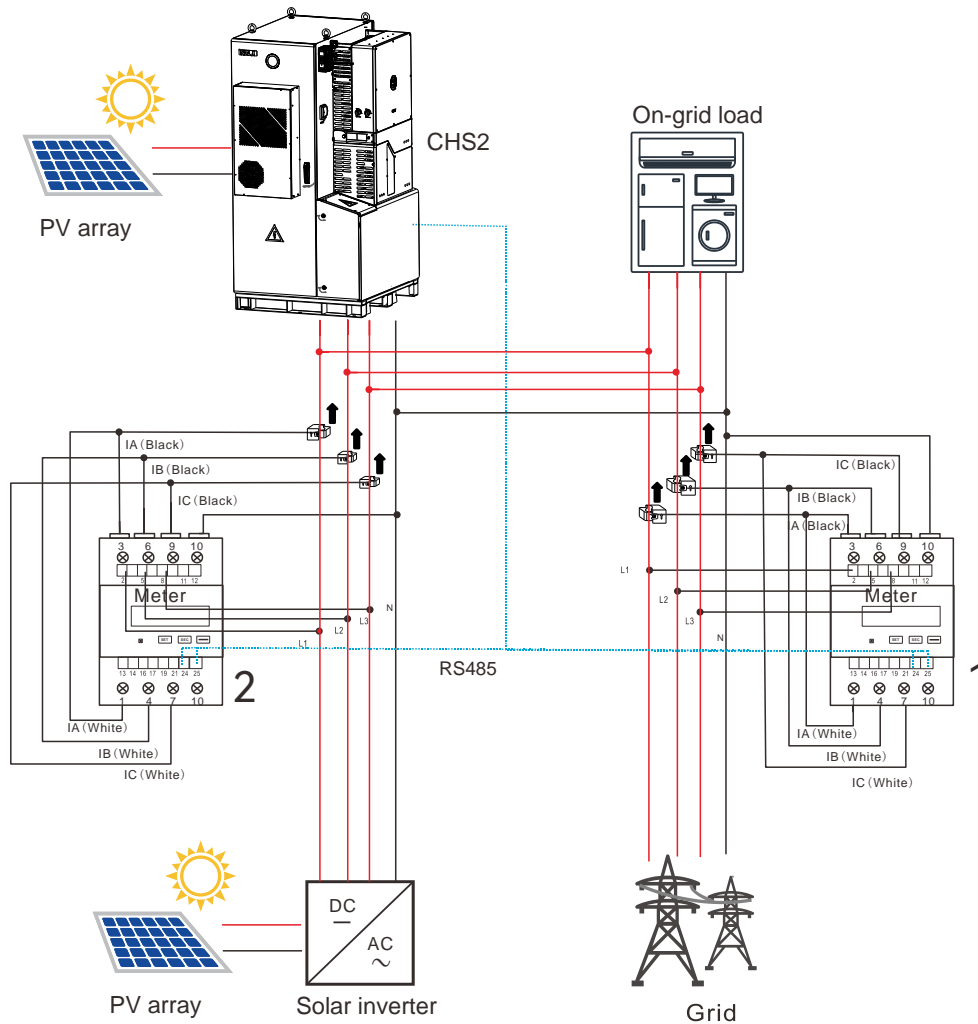

To set a three-phase meter, perform the following operations:

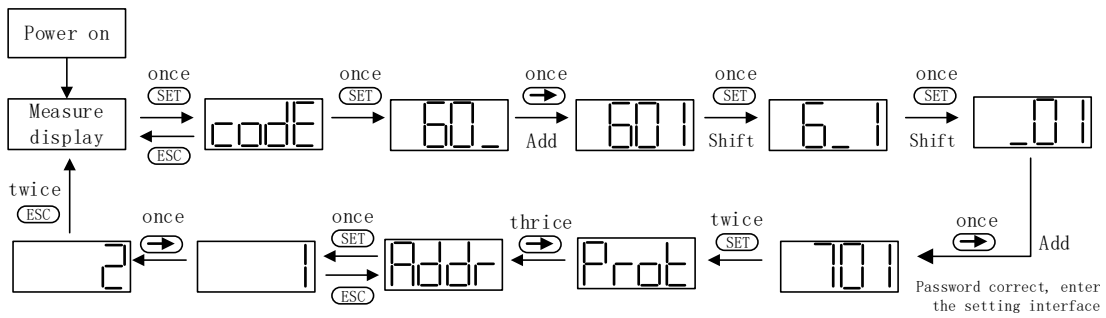

- Power on the meter and enter the "Measure display" interface, and then press **SET** twice to enter the password 701.
- Press **→** once to adjust the value of the first digit. One increment per button pressing.
- Pressing **SET** once to shift to the second digit and adjust the third digit in the same way. Set the default password to 701.
- When the password is entered correctly, press **SET** twice to enter the port interface and press **→** for three times to enter the address page. Then, press **SET** once to start to set the meter address.
- Press **→** to adjust the value of the address. One increment per button pressing.
- After the address is set successfully, press **ESC** twice to exit to the Measure display interface to get the meter work.

## 2. Dry Contact Connection

Reserved output dry contact:

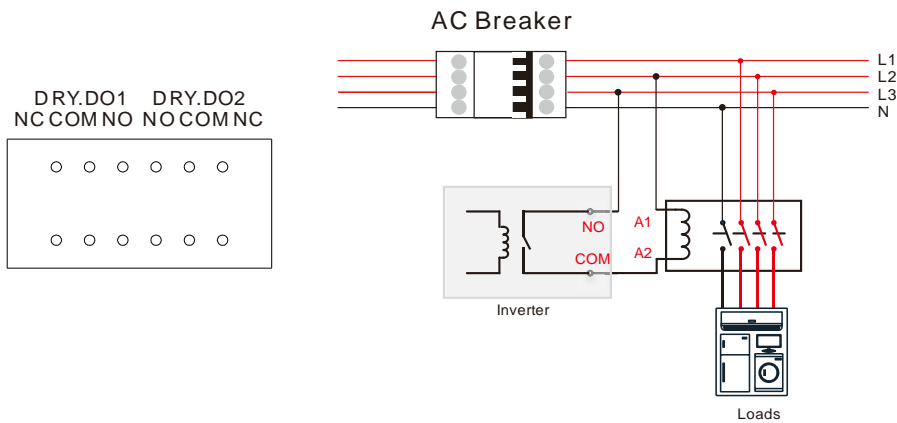

Generator start and stop control signal:

**Note:** When the inverters are used in parallel, the generator needs to be connected to the DO4 interface of the EMS device.

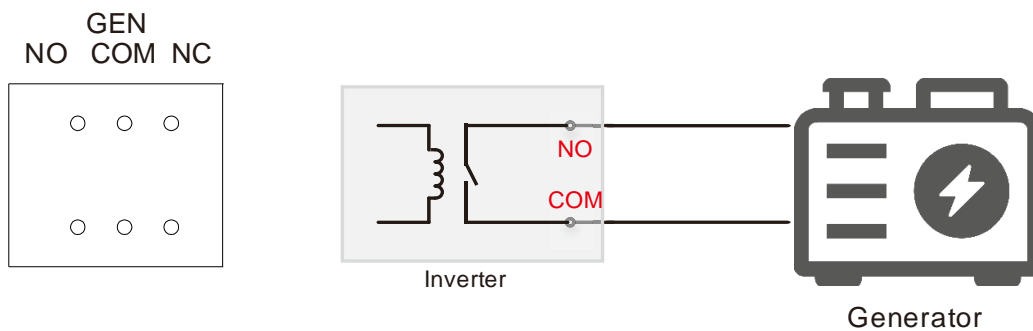



### 3. DRM Connection

DRED provides a DRED signal controlling ports to meet the Australia DERD certification requirements and other regions.

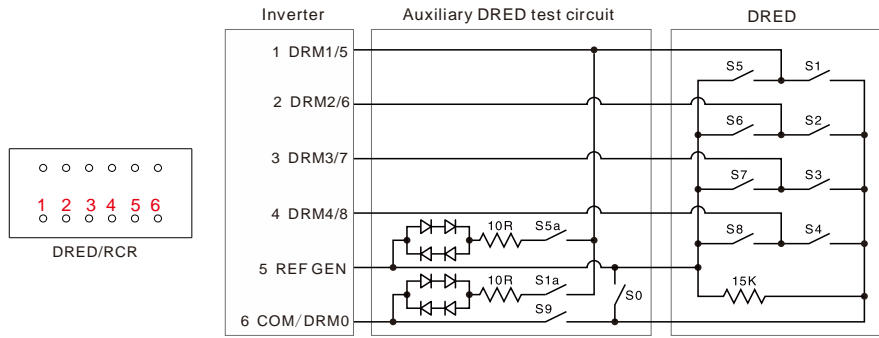

### 4. 12V Power Output

RSD\_1, RSD\_2 supplies power to the external photovoltaic fast shutdown module, and controls the power on and off by controlling the power of the module.

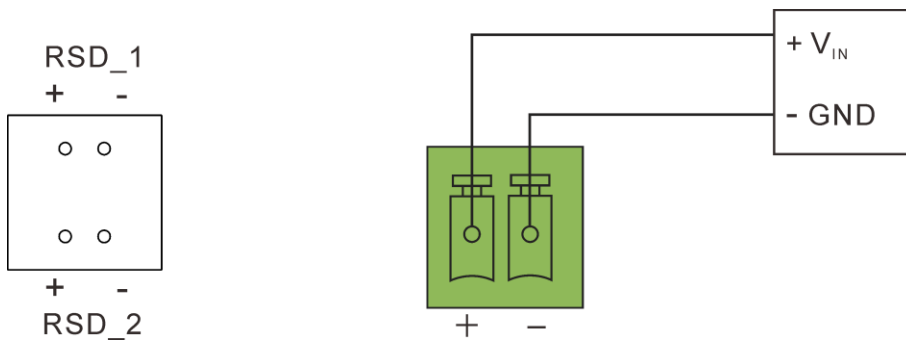

RSD\_1, RSD\_2 supplies power to the external EMS.

**Note:** The machines in the parallel machine supply power to the EMS at the same time, and the power supply equipment must be at least two inverters. RSD\_1, RSD\_2 The length of the wire supplying power to EMS equipment is limited to 6 meters.

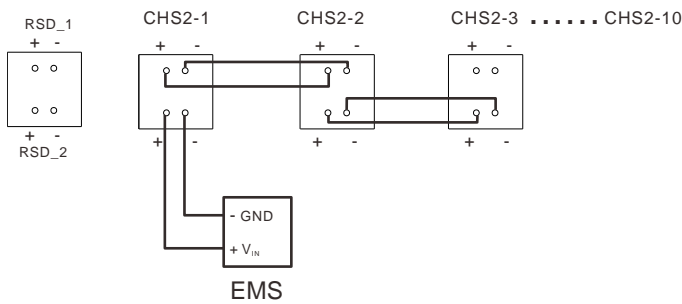

### 5. Emergency Stop Dry Contact

When + contact and - contact are shorted by external controlled switch, the inverter will stop immediately. DRY\_DI1: Reserved input dry contact.

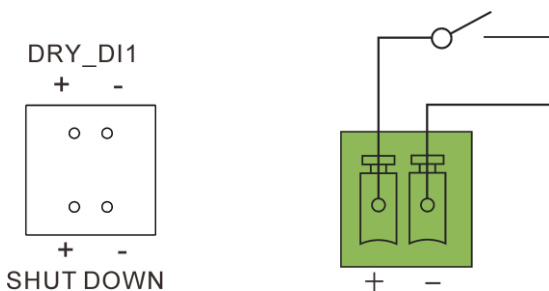

## 6. DIP switch

The DIP switch is a switch that determines whether to select the 120Ω terminal resistor.

When the inverters are used in parallel, the two inverters that are physically farthest apart need to select 120Ω terminal resistors, so the SW2 DIP switches 3 and 4 of the two inverters need to be turned to the ON position.

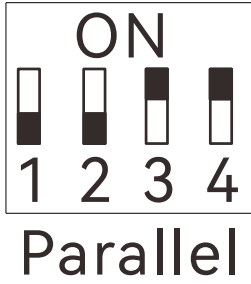

## 7. RJ45 Pin Port Definition



EMS	
1	NC
2	NC
3	NC
4	NC
5	NC
6	NC
7	RS485-A
8	RS485-B

RS485_PAR1/RS485_PAR2	
1	NC
2	NC
3	NC
4	NC
5	NC
6	NC
7	RS485-A
8	RS485-B

METER	
1	RS485-B1
2	RS485-A1
3	NC
4	RS485-B2
5	RS485-A2
6	NC
7	RS485-A3
8	RS485-B3

BMS_1/ BMS_2/ BMS_3	
1	Shut down—BMS
2	GND_S
3	NC
4	CANH
5	CANL
6	NC
7	NC
8	NC

Parelle1/ Parelle2	
1	SYN B
2	SYN A
3	SYN B
4	SYN B
5	SYN A
6	SYN A
7	CANL
8	CANH

LAN	
1	TX_D1+
2	TX_D1-
3	RX_D2+
4	BI_D3+
5	BI_D3-
6	RX_D2-
7	BI_D4+
8	BI_D4-

## 8. Communication Cable Connection

Connect the communication cables to the appropriate ports.

**Communication interface**

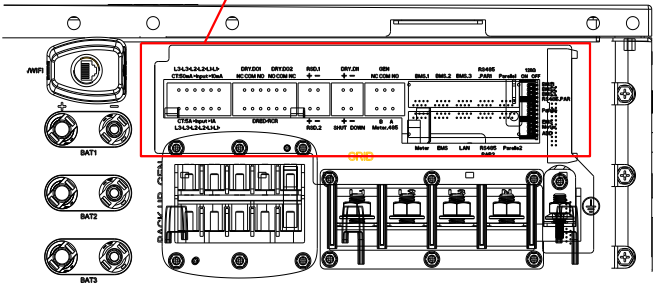

Secure all parts of the grid and backup connector tightly. Install the crossbeam suspended in the middle of the inverter and the baffle under the inverter back to their original positions.

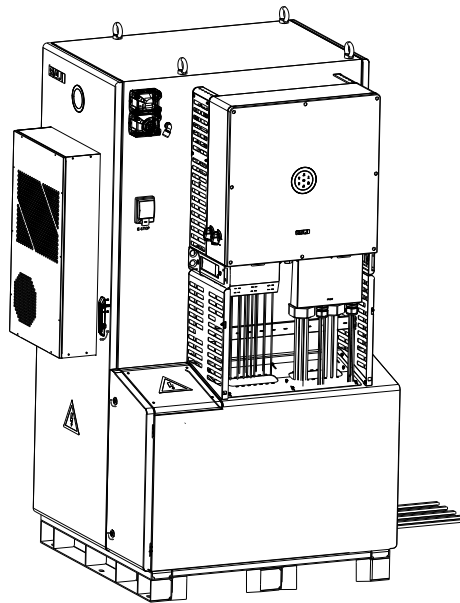

## 8. Communication Module Installation

1. Plug in the communication module to 4G/WIFI port and secure the module by rotating the nut.

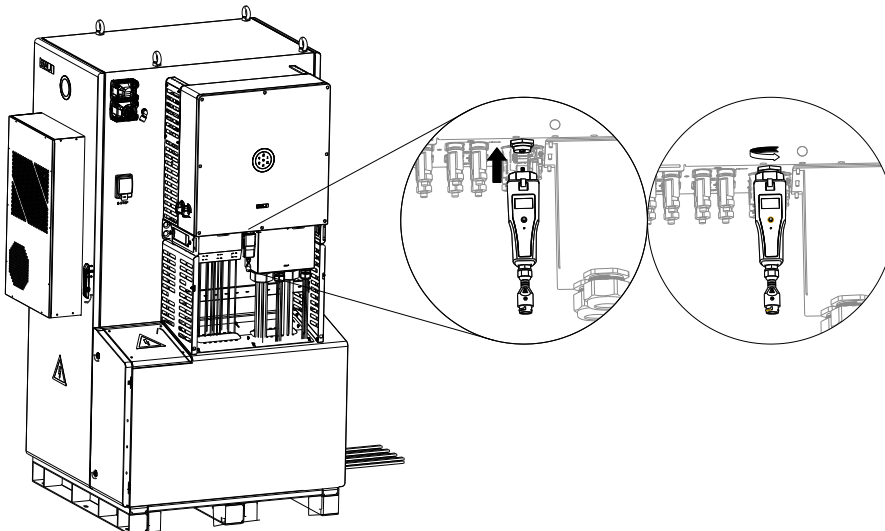

2. When the inverters are used in parallel, it needs to be connected to the EMS device for communication. For operation details, please refer to the user manual provided with the EMS Pro product.

## 9. Install Decorative Panels

Reinstall the removed panel onto the machine.

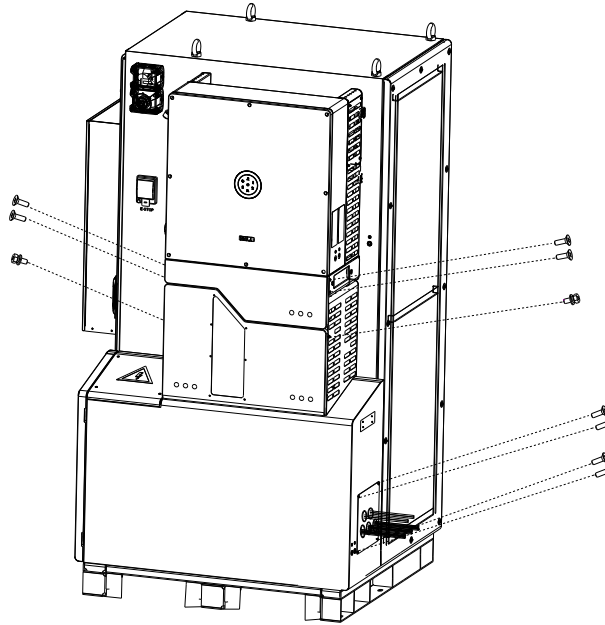

## 10. Wiring diagram

Single machine wiring:

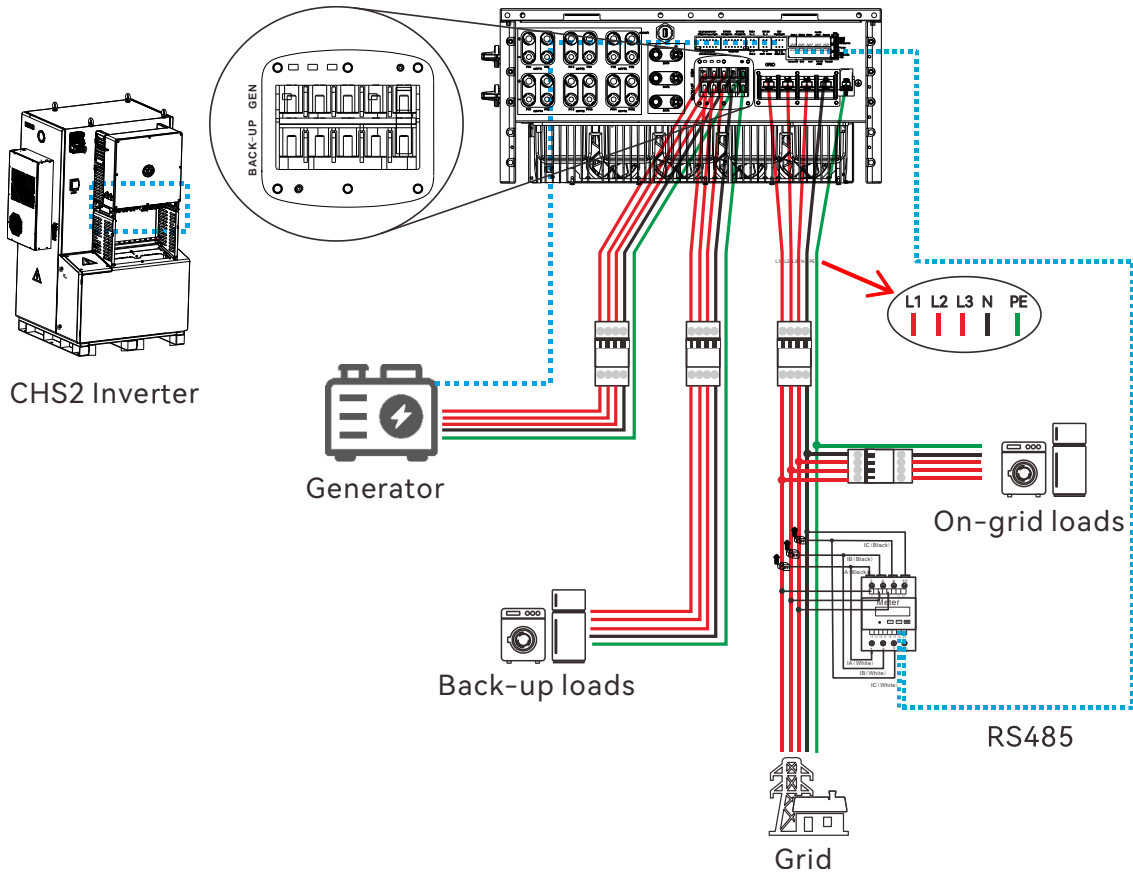

## Back-up Parallel wiring:

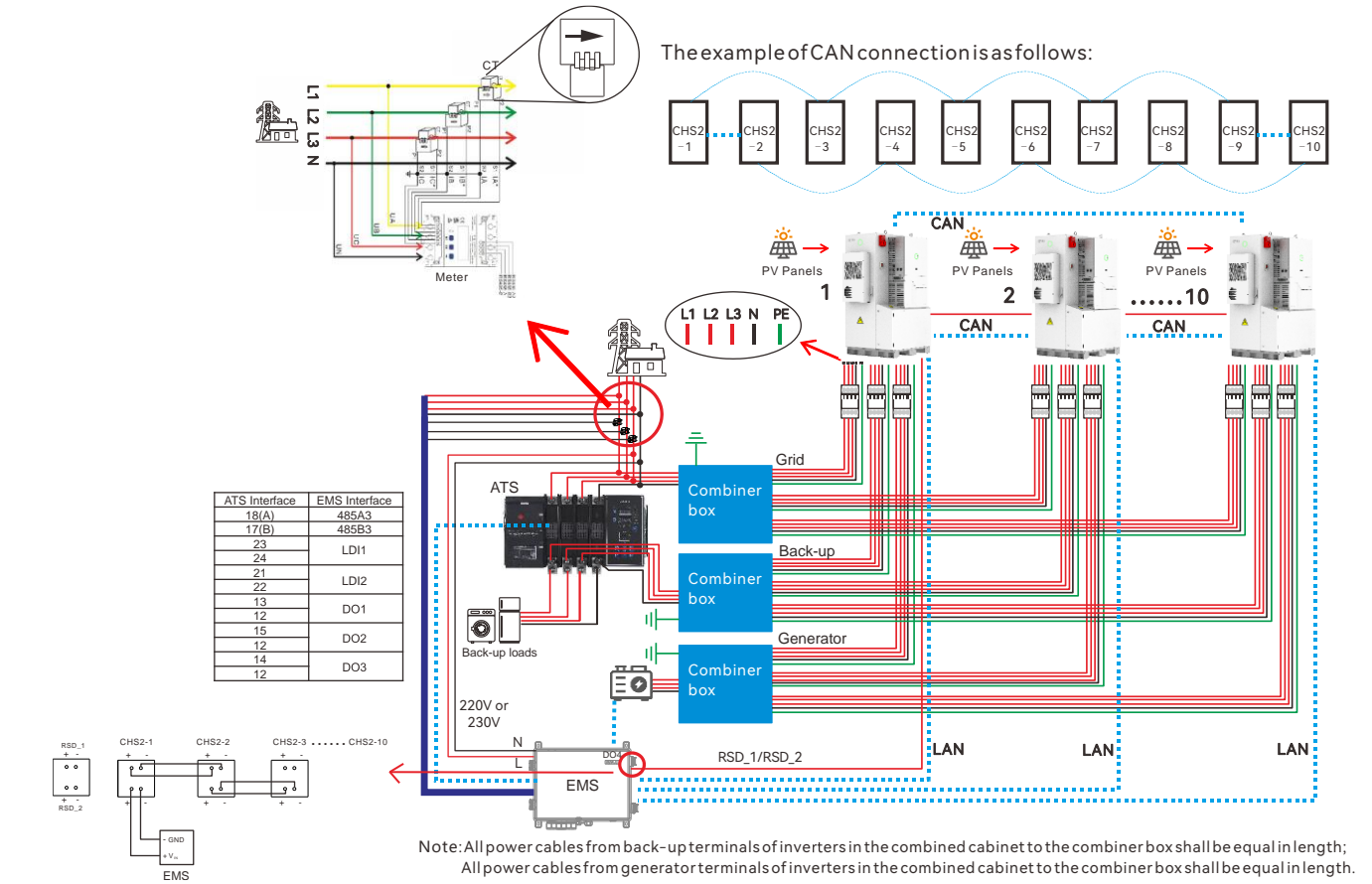

## On-grid Parallel wiring:

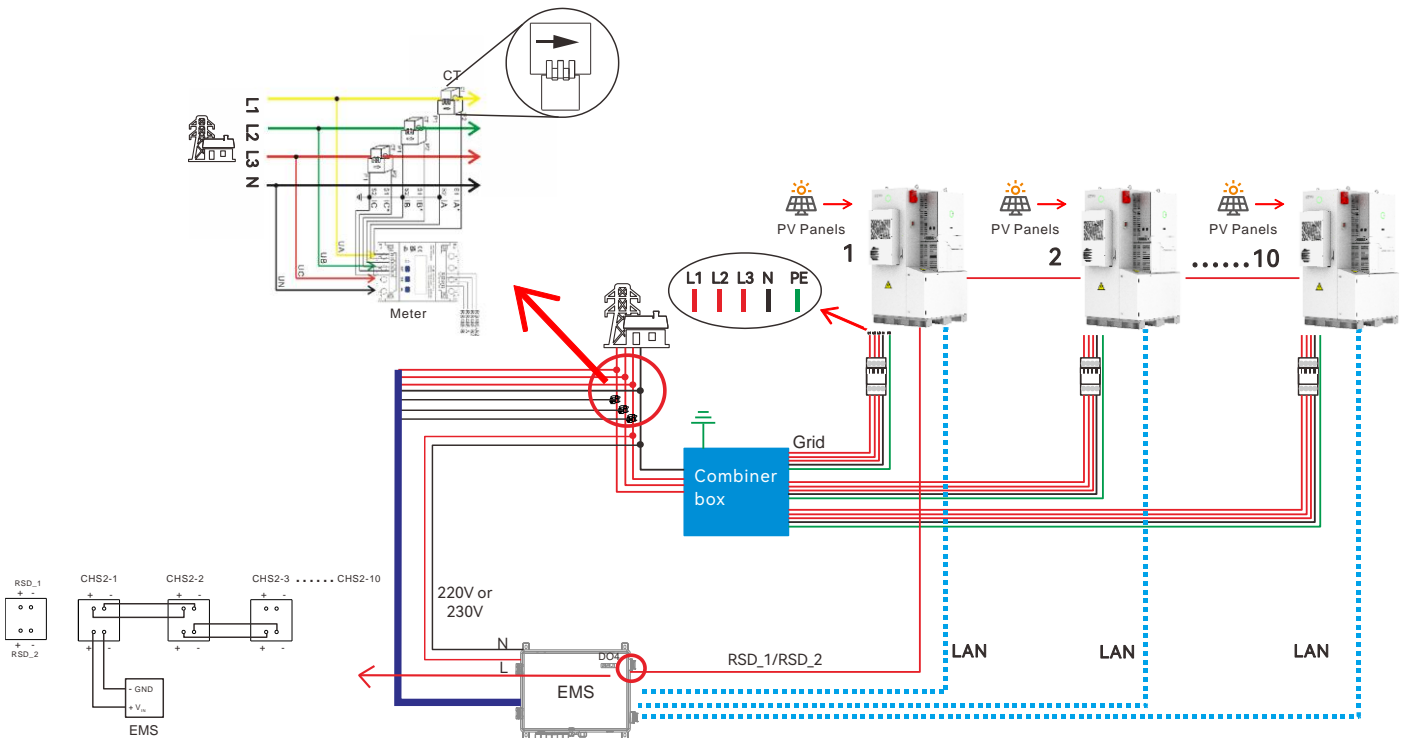

Installer: \_\_\_\_\_