

CH2 Inverter Quick Installation Guide

For more information, refer to the inverter user manual.

1. Checking Installation Ways and Gaps

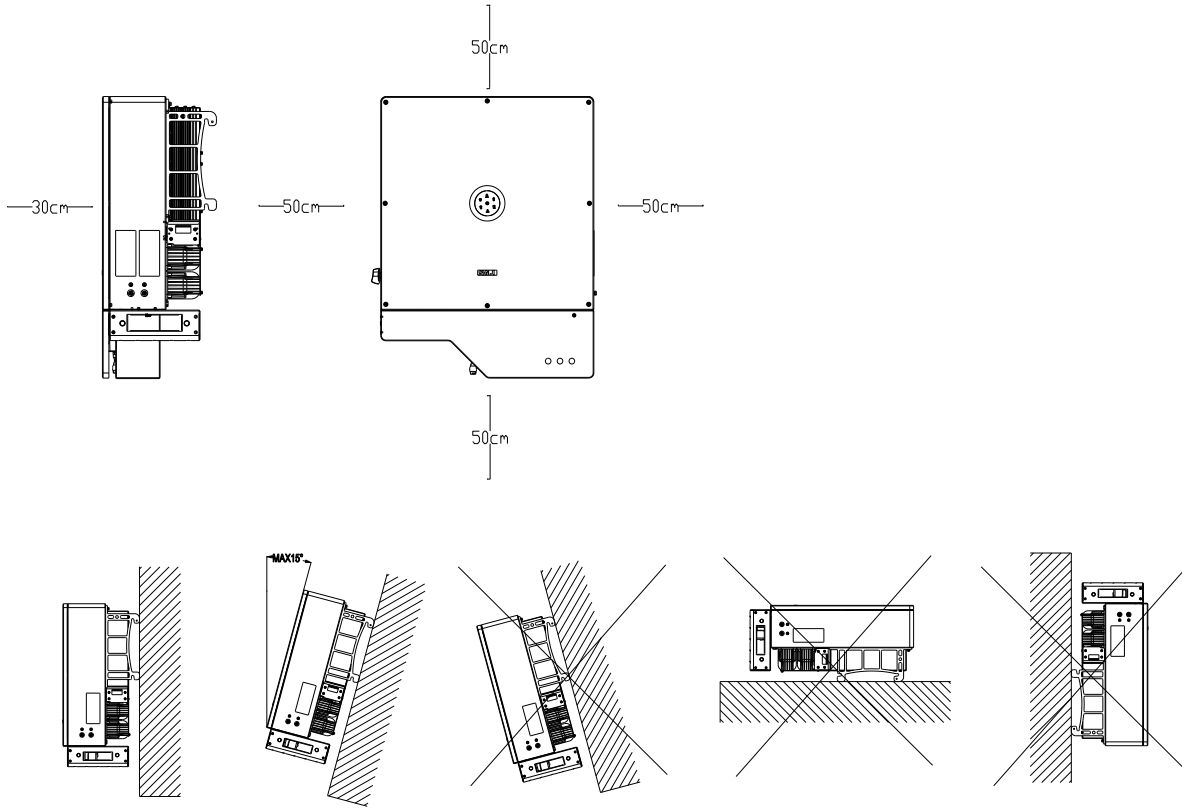

2. Installing the Inverter

1. Mark the Positions of the Drill Holes on the Rear Panel. The mounting position should be marked as shown in the following figure.

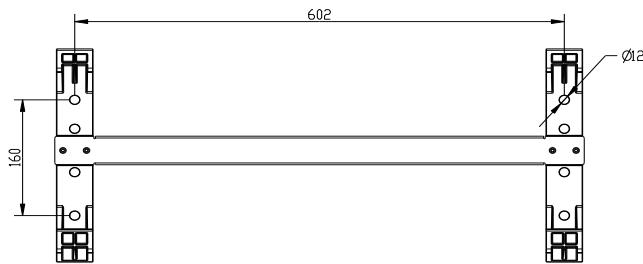

2. Drill Holes and Place the Expansion Tubes. Drill 4 holes in the wall, and then place expansion tubes in the holes using a rubber mallet.

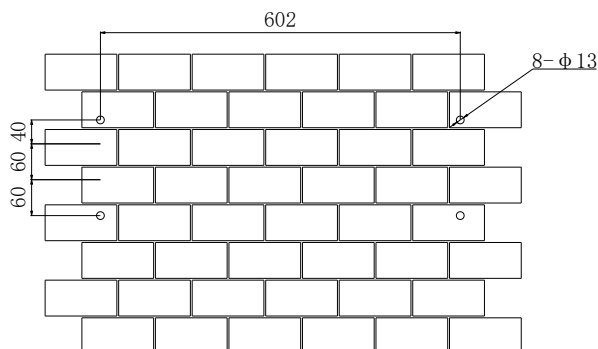

3. Secure the panels to the wall with screws.

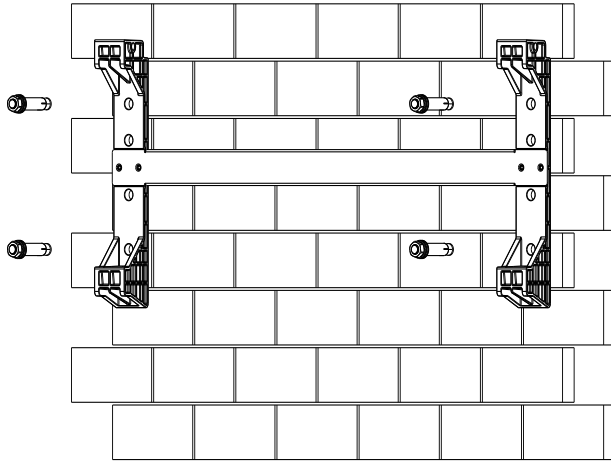

4. Mount the Inverter. Carefully mount the inverter into the rear panel as shown, Make sure that the rear part of the equipment is closely mounted into the rear panel.

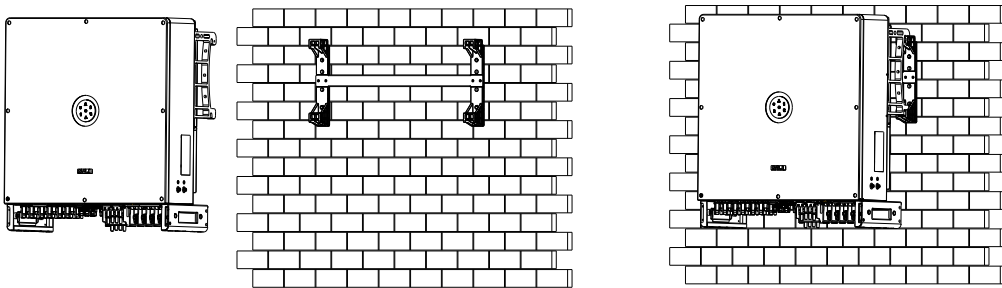

3. Additional Grounding Protection

Note: A 6 mm² conductor cross-sectional area of cable is recommended for additional grounding cable.

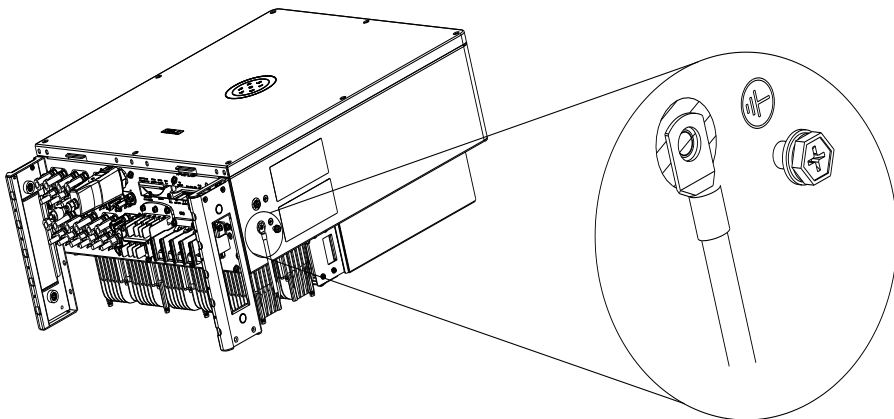

4. Communication Connection

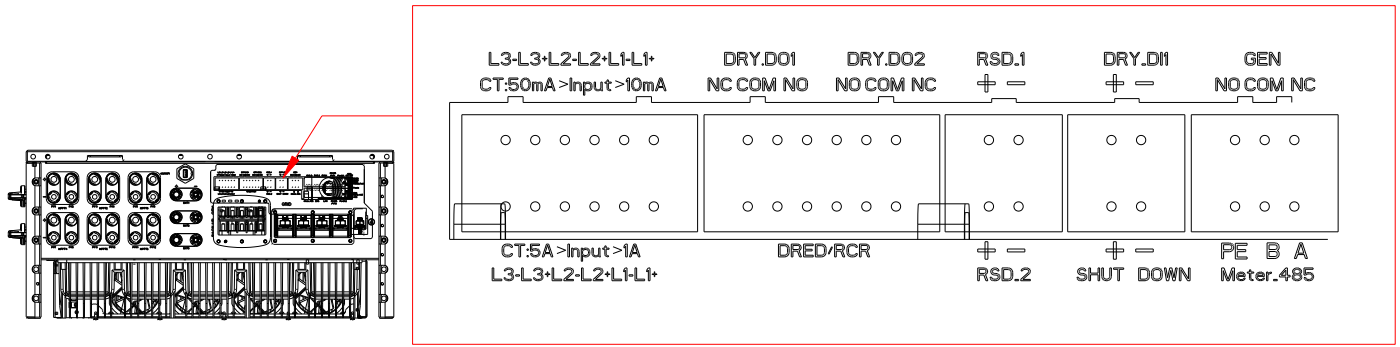

1. Export Limit Setting

The meter communication cable can be connected to the Meter_485 of the Phoenix terminal of the inverter and the METER interface of the RJ45.

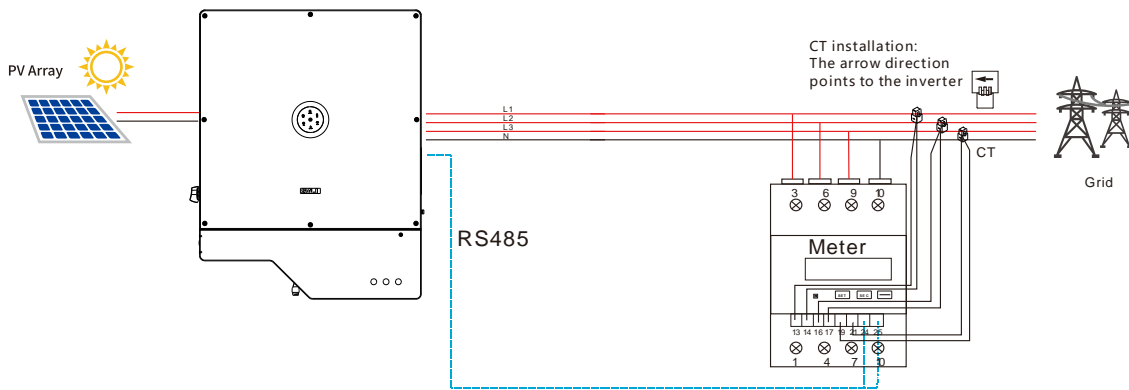

2. Dry Contact Connection

Reserved output dry contact:

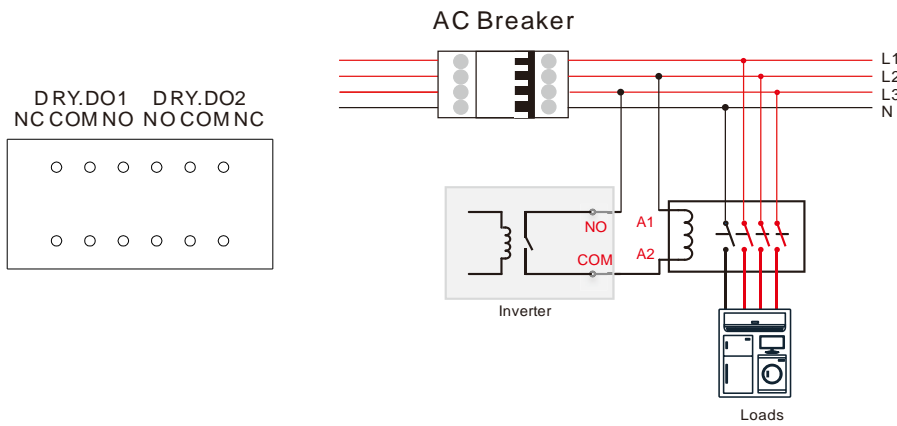

Generator start and stop control signal:

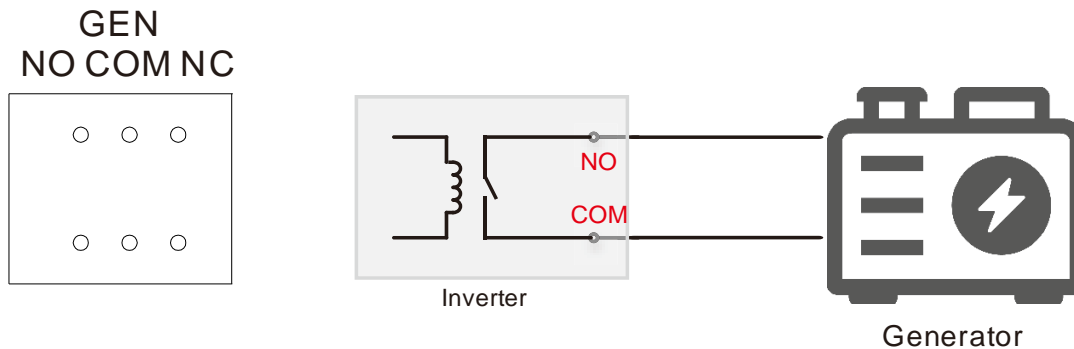

3. RCR Connection

RCR provides RCR signal control ports to meet the power grid dispatching requirements in Germany and other regions.

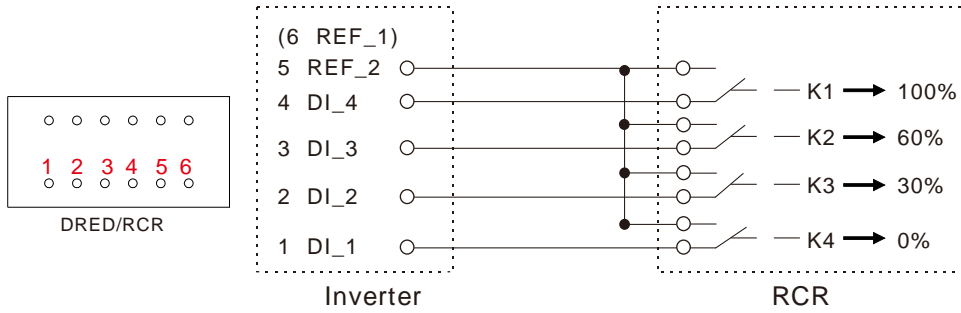

4. 12V Power Output

RSD_1, RSD_2 supplies power to the external photovoltaic fast shutdown module, and controls the power on and off by controlling the power of the module.

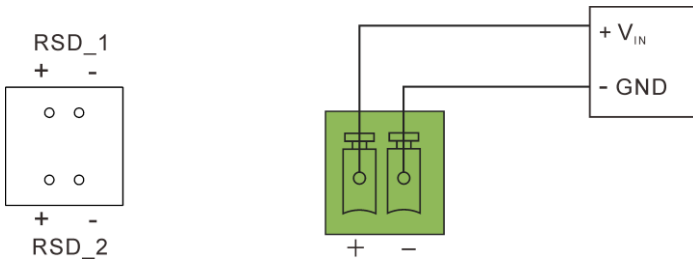

5. Emergency Stop Dry Contact

When + contact and - contact are shorted by external controlled switch, the inverter will stop immediately.
DRY_DI1: Reserved input dry contact.

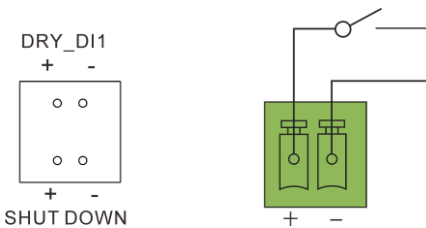

6. RJ45 Pin Port Definition



EMS	
1	NC
2	NC
3	NC
4	NC
5	NC
6	NC
7	RS485-A
8	RS485-B

RS485_PAR1/RS485_PAR2	
1	NC
2	NC
3	NC
4	NC
5	NC
6	NC
7	RS485-A
8	RS485-B

METER	
1	RS485-B
2	RS485-A
3	NC
4	RS485-B
5	RS485-A
6	NC
7	RS485-A
8	RS485-B

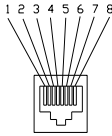
BMS_1/ BMS_2/ BMS_3		
1	Shut down—BMS	
2	GND_S	
3	NC	
4	CANH	
5	CANL	
6	NC	
7	NC	
8	NC	

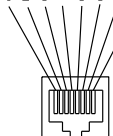
Parelle1/ Parelle2		
1	SYN B	
2	SYN A	
3	SYN B	
4	SYN A	
5	SYN B	
6	SYN A	
7	CANL	
8	CANH	

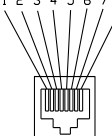
LAN		
1	TX_D1+	
2	TX_D1-	
3	RX_D2+	
4	BI_D3+	
5	BI_D3-	
6	RX_D2-	
7	BI_D4+	
8	BI_D4-	

5. Connecting the AC Cable

Recommended specifications of GRID cables:

Type	Cable cross-sectional area (mm ²)		Conductor material
	Range	Recommend	
CHS2-29.9~63K-T4/T5/T6-X	35~70	50	Copper
Grounding cable cross-sectional area (mm ²): 25			

Recommended specifications of GEN and Back-up cables:

Type	Cable cross-sectional area (mm ²)		Conductor material
	Range	Recommend	
CHS2-29.9~63K-T4/T5/T6-X	16~25	25	Copper
Grounding cable cross-sectional area (mm ²): 25			

Note: If the grid-connection distance is too far, please select an AC cable with larger diameter as per the actual condition.

1. Pass the cables to be connected through the corresponding waterproof holes.

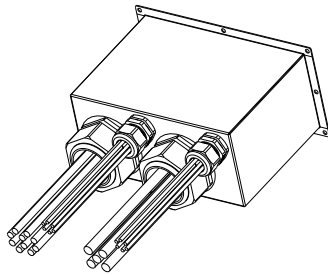

2. Connect the communication cable to the corresponding port. GRID, GEN and Back-up Fix the cables according to conductor marks of L1, L2, L3, N and PE.

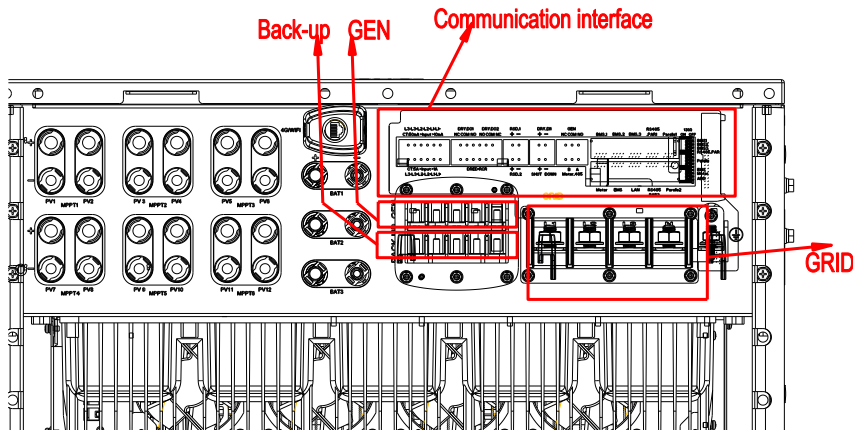

- Secure all parts of the grid and backup connector tightly.

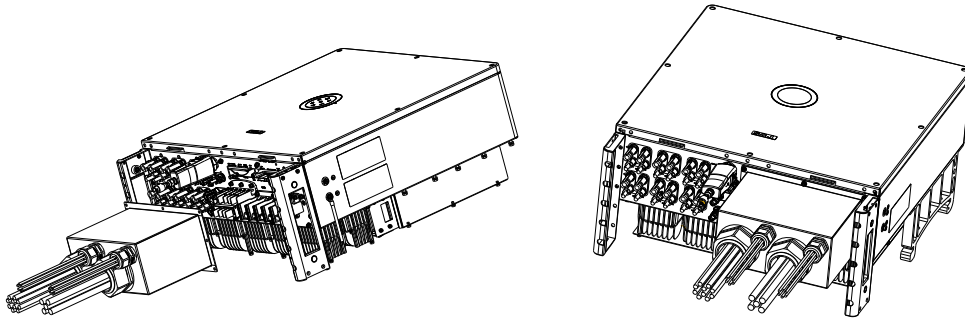

- During off grid operation time, PE line at the BACK-UP end will remain to be connected with the PE line at the power grid end inside the inverter. (Only applicable to market in Australia)

6. PV Side Connection

Recommended specifications of DC cable

Conductor cross-sectional area of cables (mm ²)		Conductor material
Scope	Recommended value	Outdoor multi-core copper wire cable, complying with 1000Vdc
4.0~6.0	4.0	

- Loosen the lock screws on positive and negative connector.
- Strip the insulation of the positive and negative cables with 8-10mm length.

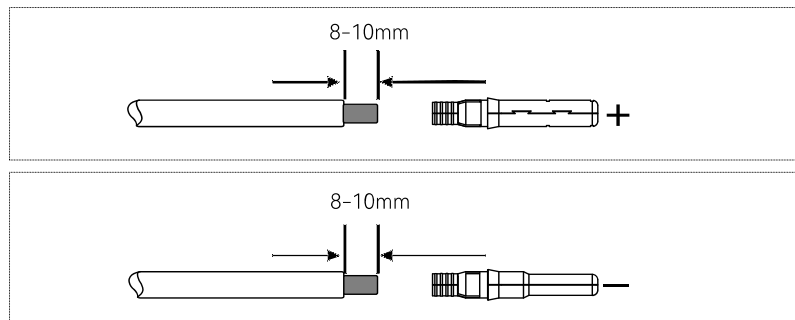

- Assembly the positive and negative cables with corresponding crimping pliers.

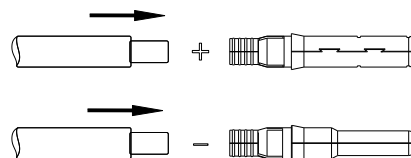

- Insert the positive and negative cable into positive and negative connector. Gently pull the cables backward to ensure firm connection.

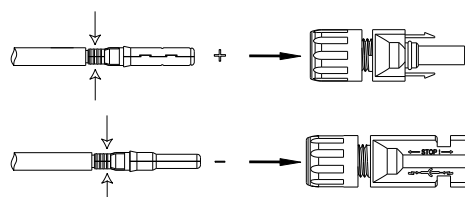

5. Fasten the lock screws on positive and negative connectors.

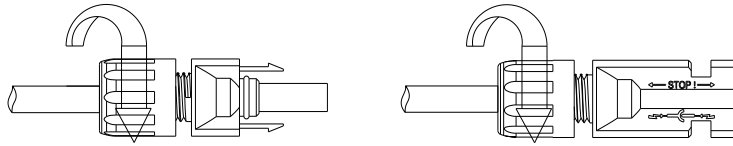

6. Make sure the DC switch is at OFF position.

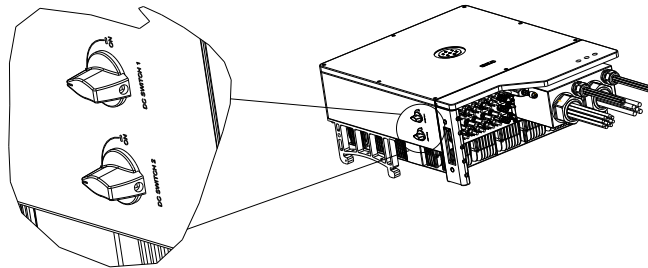

7. Connect the positive and negative connectors into positive and negative DC input terminals of the inverter, a “click” should be heard or felt when the contact cable assembly is seated correctly.

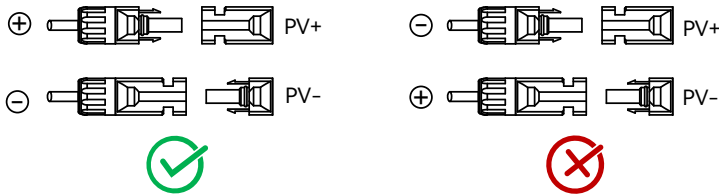

7. Communication Module Installation

Plug in the communication module to 4G/WIFI port and secure the module by rotating the nut.

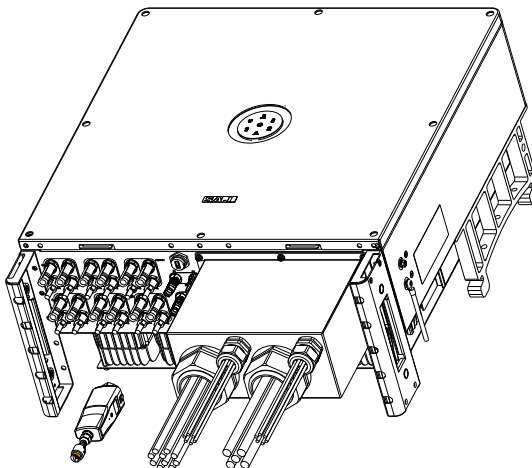

8. Battery Connection

If lithium battery is connected, it is not required to install a breaker between battery and inverter.

Cable Cross-sectional area (mm ²)	
Range	Recommend
8~10	10

1. Get the waterproof cover from the accessory bag and cut holes in the rubber plug. Insert the positive and negative cables through the hole.
2. On both cables, use a 3-mm wide-bladed screwdriver to strip the insulation layer around 8 to 10 mm length from one cable end.
3. Insert the cable ends to the corresponding sleeves. Use a crimping plier to assembly the cable ends.
4. Insert the assembled cable ends into the blue positive and negative battery connectors. Then, gently pull the cables backwards to ensure that they are firmly connected.
5. Tighten the nuts on the positive and negative cable connectors.

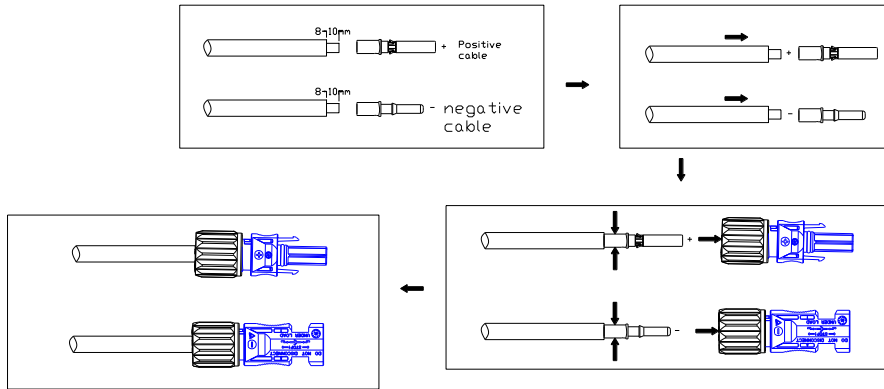

6. Fix the battery cable on the battery copper terminal by positive and negative in order.

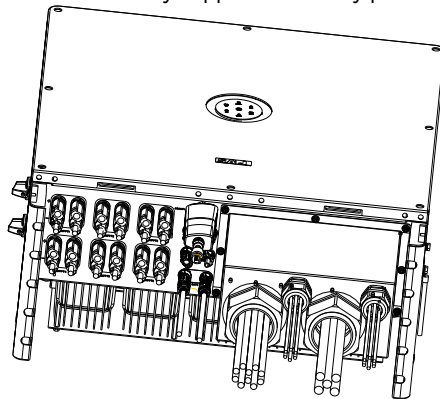

9. Install Decorative Panels

Take out the decorative board, place the decorative board stably at the position shown in the figure below, and fix it with screws.

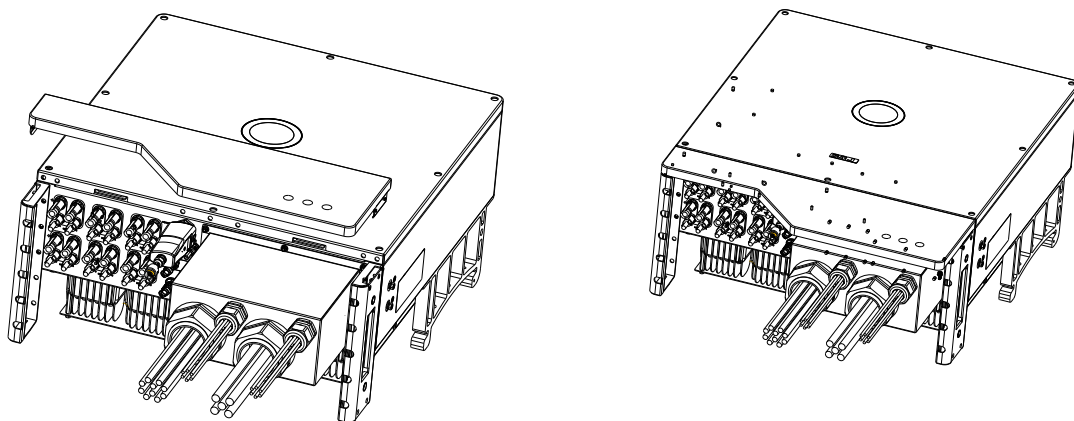

Installer: _____