











ATS Box Quick Guide

This quick guide provides the instructions for installing, operating, and maintaining SAJ product ATS1-T63-A.

NOTICE

- Before installation, operation, and maintenance, read the product documentation carefully.
- ONLY qualified and trained electricians who have read and fully understood all safety regulations contained in this manual can install, maintain, and repair the equipment. The operation personnel should understand the system, its working principles, and relevant national and regional standards.
- During operations, wear protective equipment and use dedicated tools.

Safety Symbol Explanation

Symbol	Description
	Danger: Electrical shock hazard This device is directly connected to public grid and thus all work to the battery shall only be carried out by qualified personnel.
	WARNING: No open flames Do not place or install near flammable or explosive materials.
	Danger: Hot surface The components inside the battery will release a lot of heat during operation. Do not touch metal plate housing during operating.
	Attention: Install the product out of reach of children.
	Attention: Check the user manual before service. If an error has occurred, refer to the troubleshooting chapter to remedy the error.
	Attention: This device shall NOT be disposed of in residential waste.
	CAUTION: Risk of electric shock from energy stored in capacitor. Do not remove cover until 5 minutes after disconnecting all sources of supply.
	CE Mark Equipment with the CE mark fulfills the requirements of the Low Voltage Directive and Electro Magnetic Compatibility.
	RoHS compliant mark Equipment with the RoHS mark does not exceed the allowable amounts of the restricted substances defined in Restriction of Hazardous Substances in Electrical and Electronic Equipment.
	RCM compliant mark Equipment with the RCM mark is in compliance with AS/NZS 4417.1 & 2 and the EESS.
	Recyclable

Safety Instructions

For safety, be sure to read all the safety instructions carefully prior to any works, and follow the safety rules and regulations of the country or region where you install the product.

⚡ DANGER

- Possible fatal personnel injuries due to electrical shock and high voltage.
- Do not touch the surface of the equipment while the housing is wet, otherwise, it might cause electrical shock.
- Do not touch the operating components that are covered by the insulation cover; it might result in burning or death.
- Do not stay close to the equipment while there are severe weather conditions including storm, lightning, etc.
- Keep the power off prior to any installation or maintenance operations.

⚠ WARNING

- Any unauthorized actions including modification of product functionality of any form may cause lethal hazard to the operator, third parties, the units or their property. SAJ is not responsible for the loss and these warranty claims.
- Do not touch non-insulated parts or cables.
- Disconnect the AC circuit breaker, or keep it disconnect if it is tripped, and secure it against reconnection.
- Be sure that the product is well grounded to protect properties and persons.

Product Introduction

The SAJ ATS box integrates with multiple power sources and automatic load switch in the photovoltaic (PV) energy storage system (ESS) to ensure continuous power supply to loads with higher priority.

For ATS1-T63-A equipped with the eManager module, the ATS can integrate with the grid, SAJ hybrid inverters, and on-grid inverters of SAJ or other manufacturers. When the grid is available, the ATS supplies electricity to both the on-grid and off-grid loads from the integrated power sources; if the grid fails, the ATS continues to supply electricity to the off-grid loads from the backup output of hybrid inverters while disconnecting the on-grid loads.

The following figure shows the system diagram of ATS1-T63-A equipped with the eManager module:

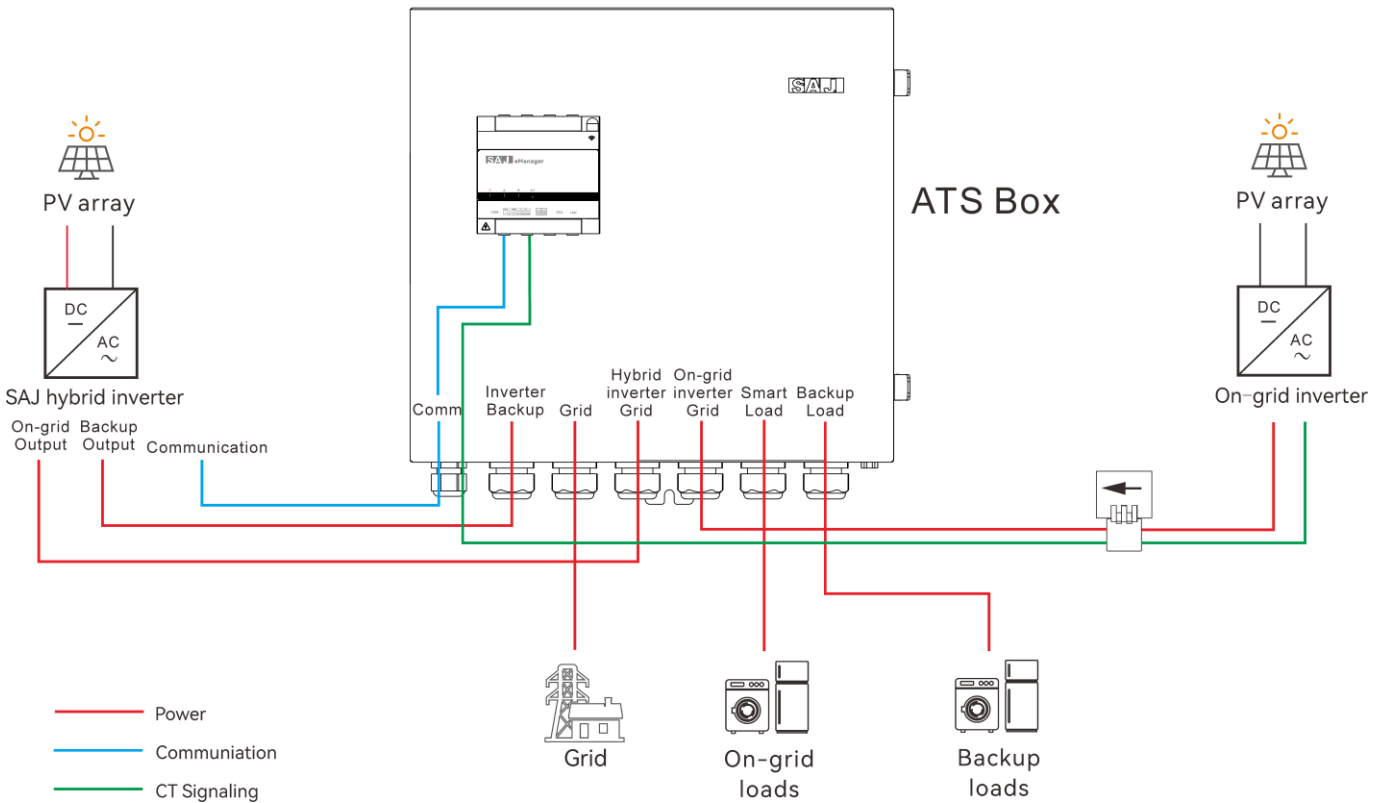

Figure 1.1. System connections – ATS with eManager

Installation Procedures

1. Check the outer packing

1. Check the outer packing package for any damage, such as holes and cracks.
2. Check the equipment model.

If any serious damage is found or the model is not what you requested, do not unpack the product, and contact your dealer as soon as possible.

2. Check the product package

- Package of ATS1-T63-A

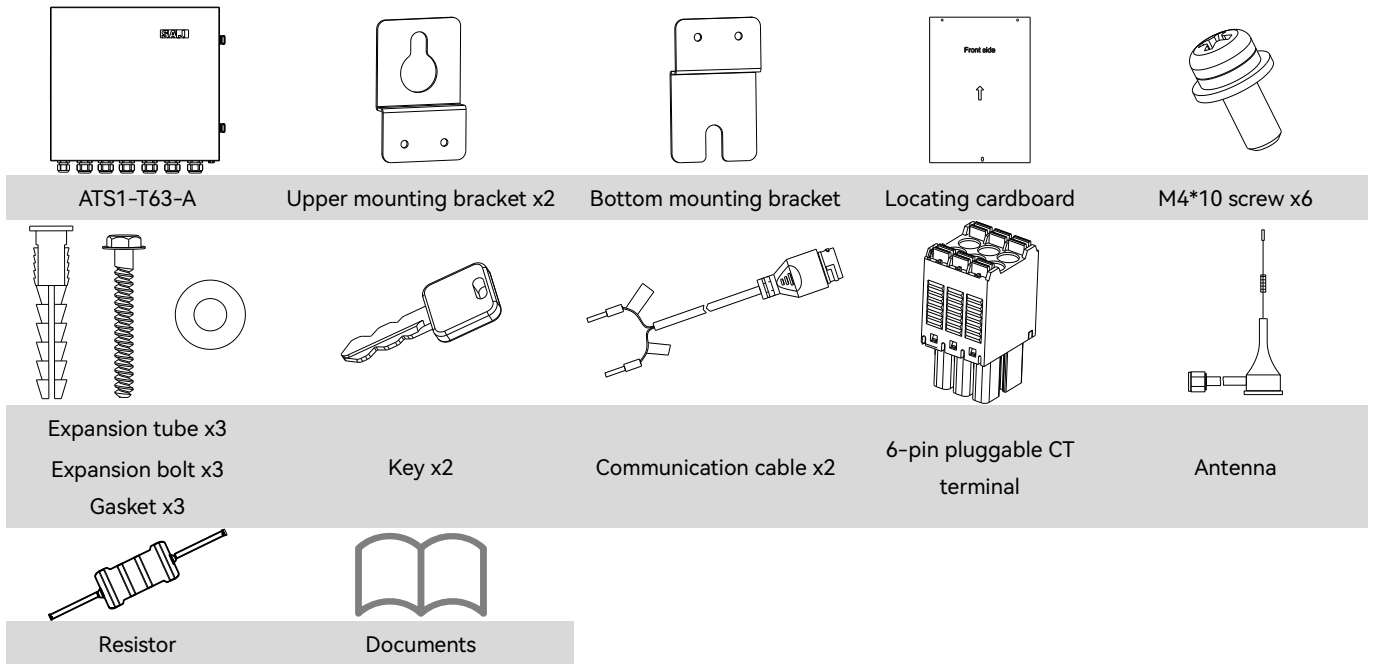

3. Plan the installation site

The device employs natural convection cooling, and it can be installed indoor or outdoor.

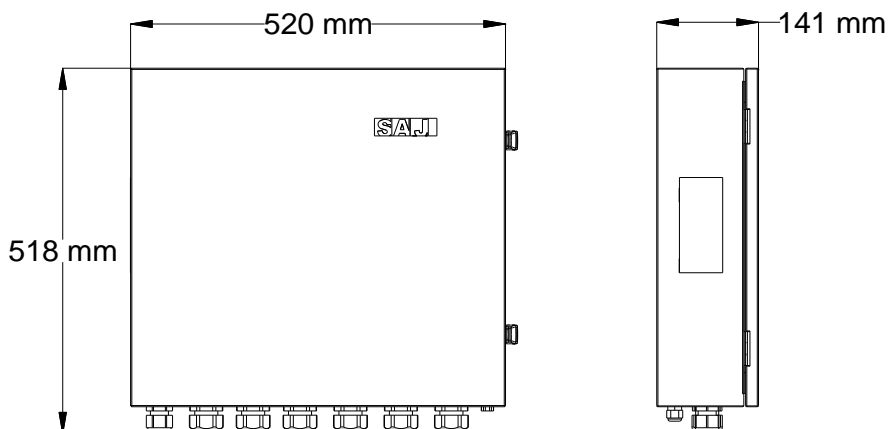

Reserve enough space around the ATS box to ensure ventilation and convenience of operation.

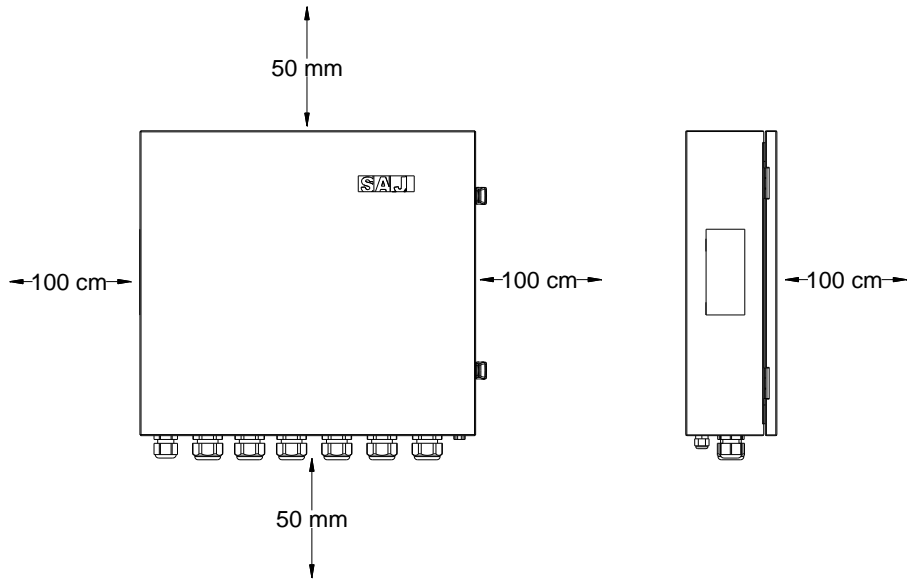

□ 4. Mount the ATS box

Step 1. Put the locating cardboard on the wall where the ATS box will be installed with the front side facing outwards. Mark and drill three drilling holes according to the markings on the cardboard.

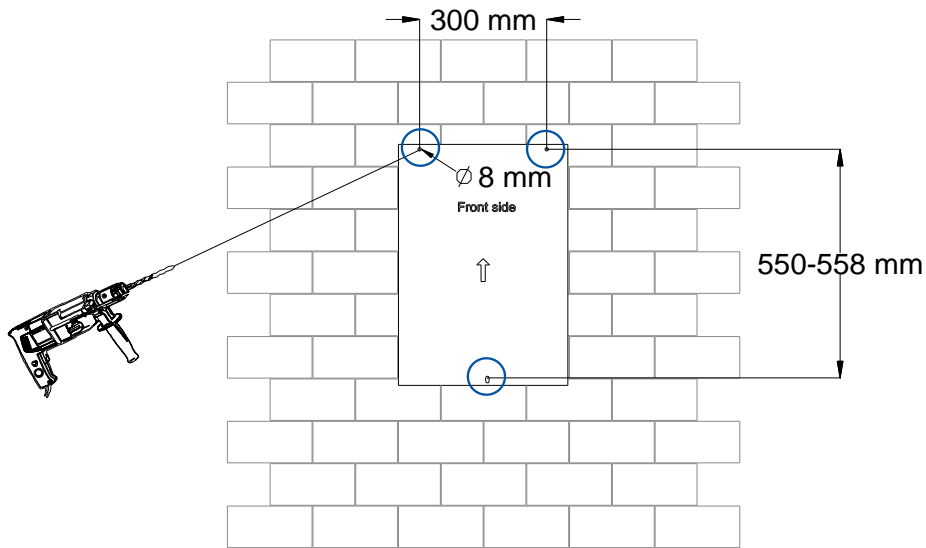

Step 2. Insert the expansion tubes into the holes with a rubber magnet.

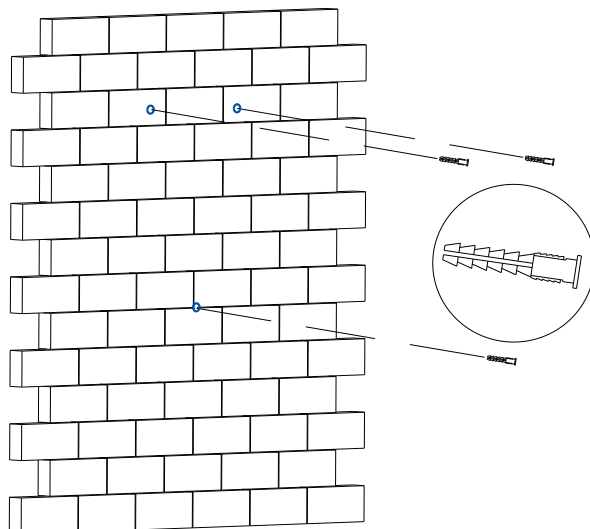

Step 3. Insert the expansion bolts into the expansion tubes, leaving around 5-10 mm outside the wall surface.

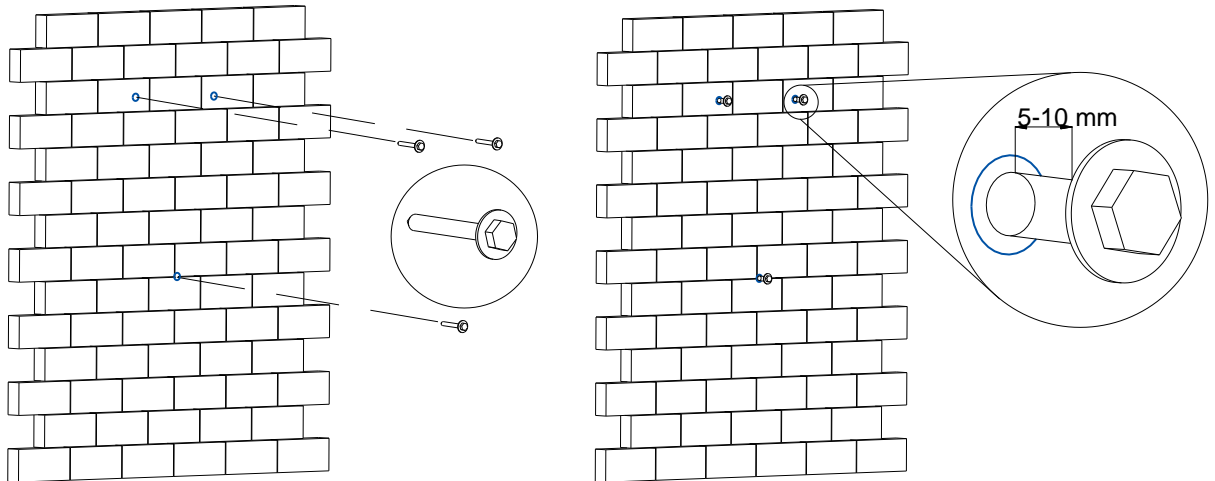

Step 4. Secure the upper and bottom mounting brackets on the back of the ATS box. Secure each bracket with two screws.

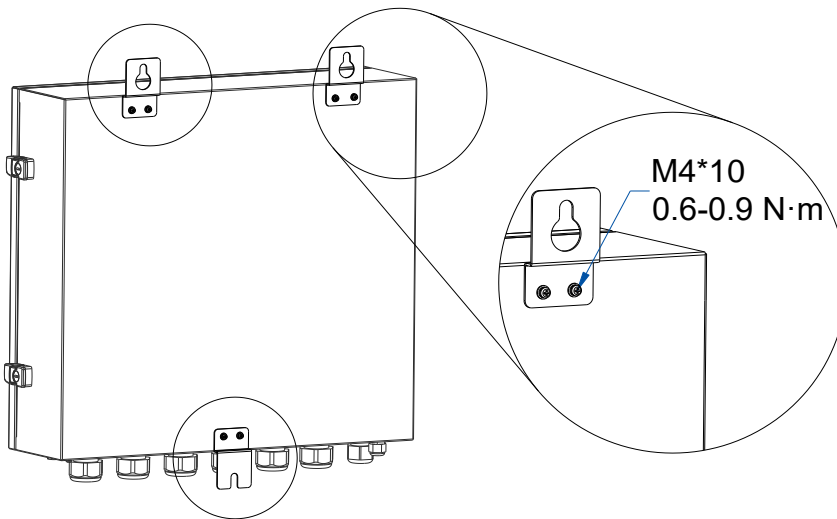

Step 5. Mount the ATS box onto the three expansion bolts on the wall.

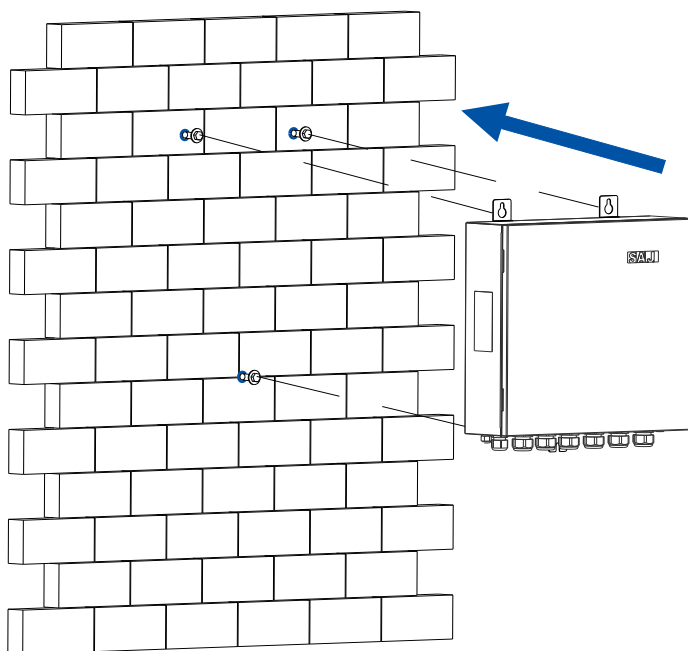

Step 6. Slide the ATS box down along the hole of the mounting bracket to secure the box.

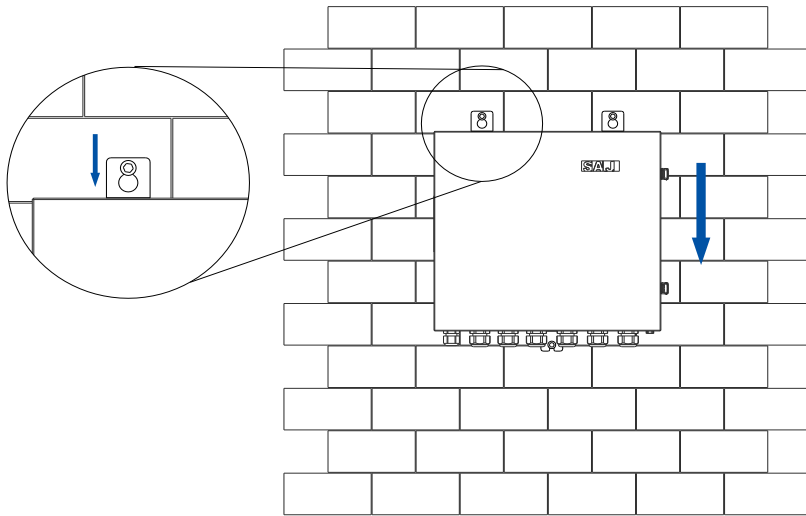

Step 7. Tighten the three expansion bolts to secure the mounting brackets to the wall.

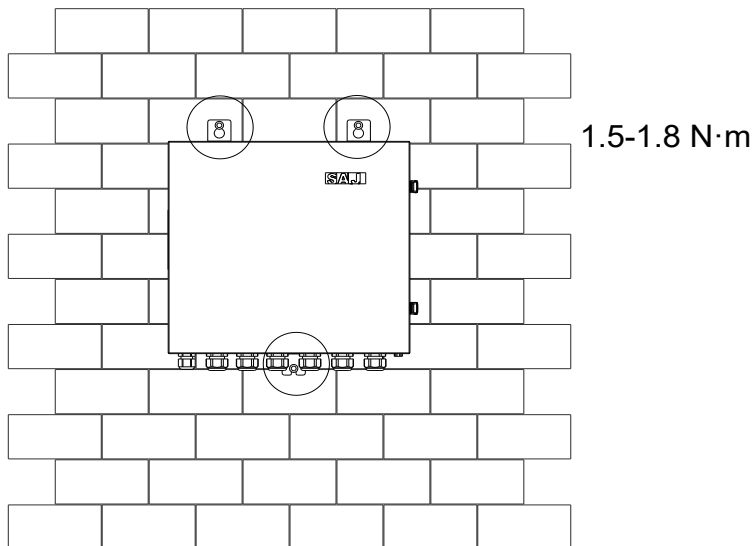

□ 5. Cable connections

5.1 Electrical interfaces description

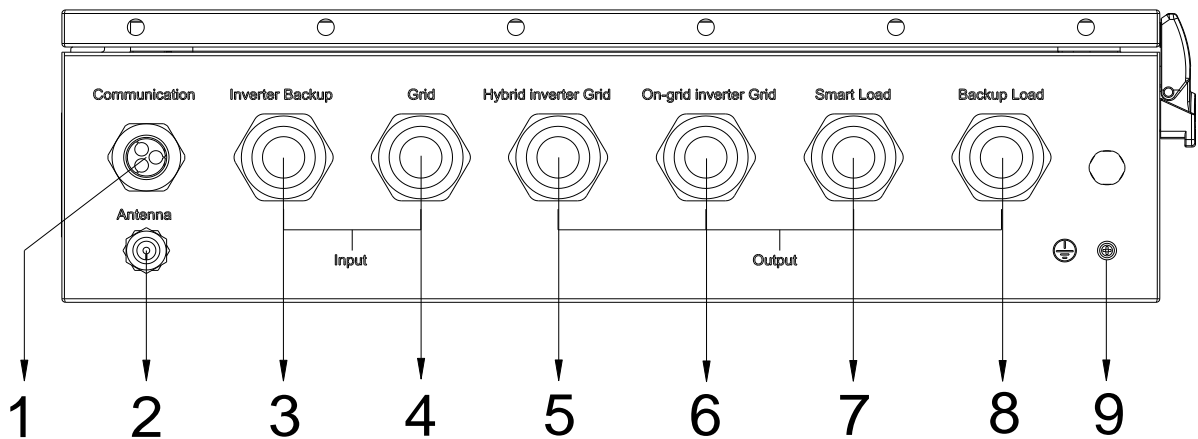

Figure 5.1. Electrical interfaces

Callout	Silkscreen	Description
1	Communication	For the communication cable between ATS and the inverters.
2	Antenna	For the antenna connection for the eManager module.
3	Inverter Backup	For the AC cable connections from the backup output of hybrid inverters to supply electricity to the off-grid loads.
4	Grid	For the AC cable connections from the grid to supply electricity to both the on-grid and off-grid loads.
5	Hybrid Inverter Grid	For the AC cable connections from the on-grid output of hybrid inverters.
6	On-grid Inverter Grid	For the AC cable connections from the on-grid output of on-grid inverters. The electricity is supplied to both the on-grid and off-grid loads.
7	Smart Load	For the AC cable connections to supply electricity to the on-grid loads.
8	Backup Load	For the AC cable connections to supply electricity to the off-grid loads.
9	Grounding	For the grounding cable connection.

Table 5.1. Description of the electrical interfaces

5.2 Connect the grounding cable

Step 1. Prepare a grounding cable of 6-10 AWG and an RNBS5-4 terminal for cable connection.

Step 2. Use the key to open the ATS box.

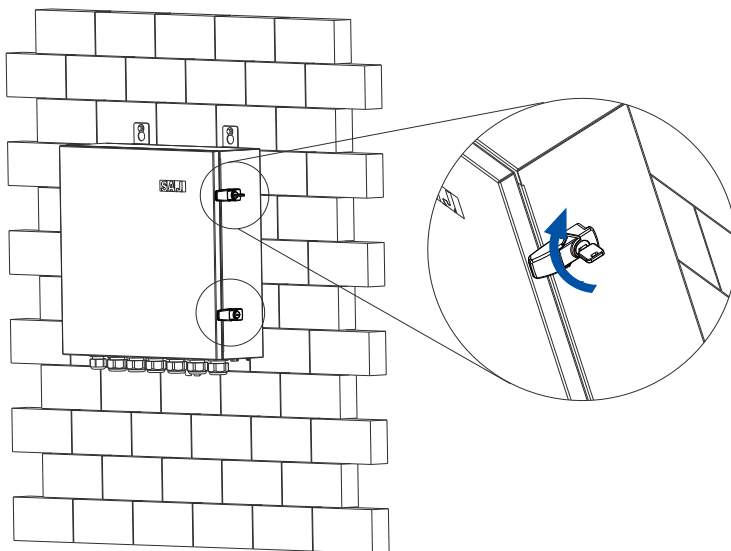

Step 3. Crimp the grounding cable with the RNBS5-4 terminal. Connect the grounding cable on the bottom of the ATS box.

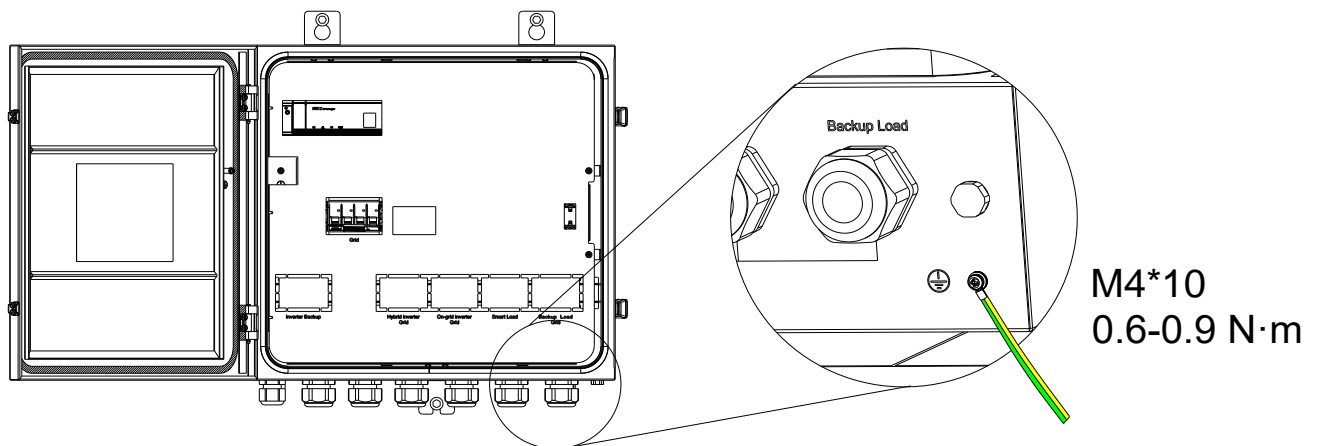

Step 4. Loosen the two screws to remove the insulation cover in the box.

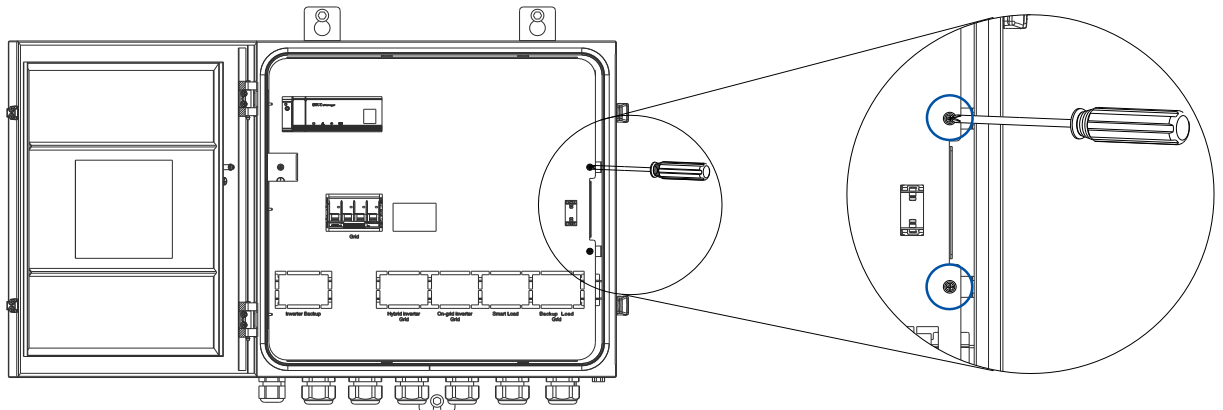

5.3 Connect the eManager module cables

The 12V power supply of the eManager module is connected by default. Take the steps below to connect the antenna and communication cables. For the communication cable, connect the RS485 or LAN cables depending on the inverter model.

Step 1. Insert the screw end of the antenna cable through the **Antenna** cable gland at the bottom of the ATS box, pass the cable through the left side inside the box, and secure the cable end on the right top of the eManager module.

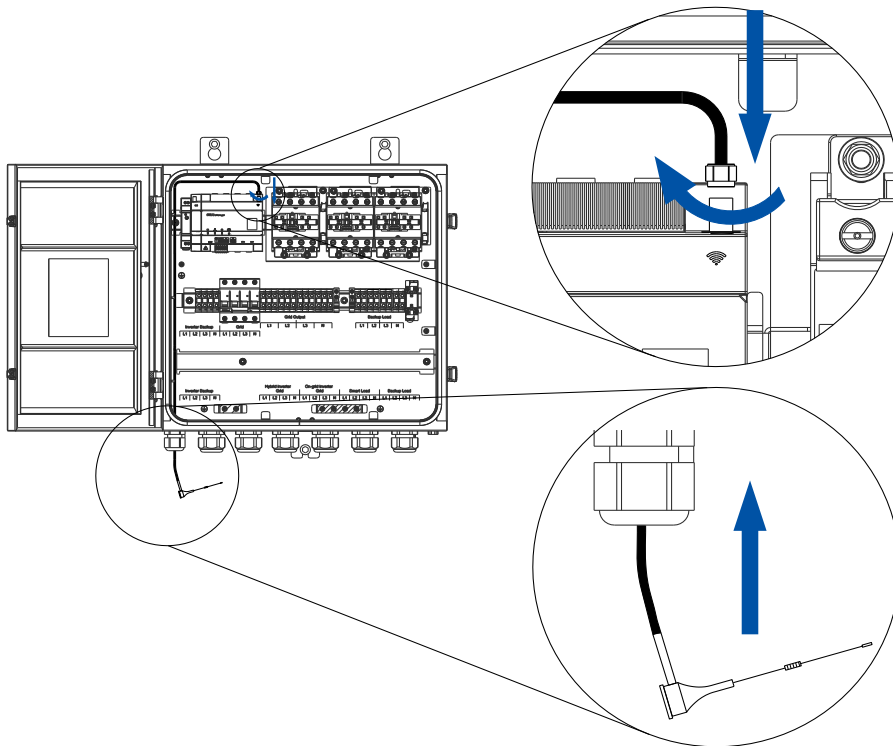

Step 2. Pass the antenna through the outside cover of the ATS box, and stick the antenna on top of the box.

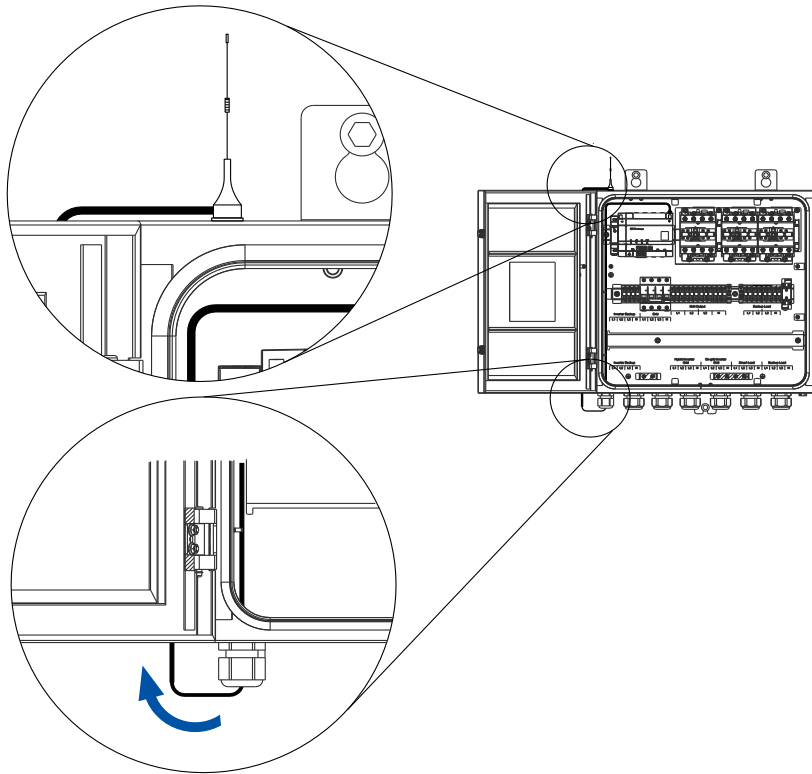

Step 3. Prepare a Category 5 or 6 communication cable between the hybrid inverter and ATS with a RJ45 plug on both ends. On the ATS side, pass one end of the cable through the **Communication** cable gland alongside the antenna cable.

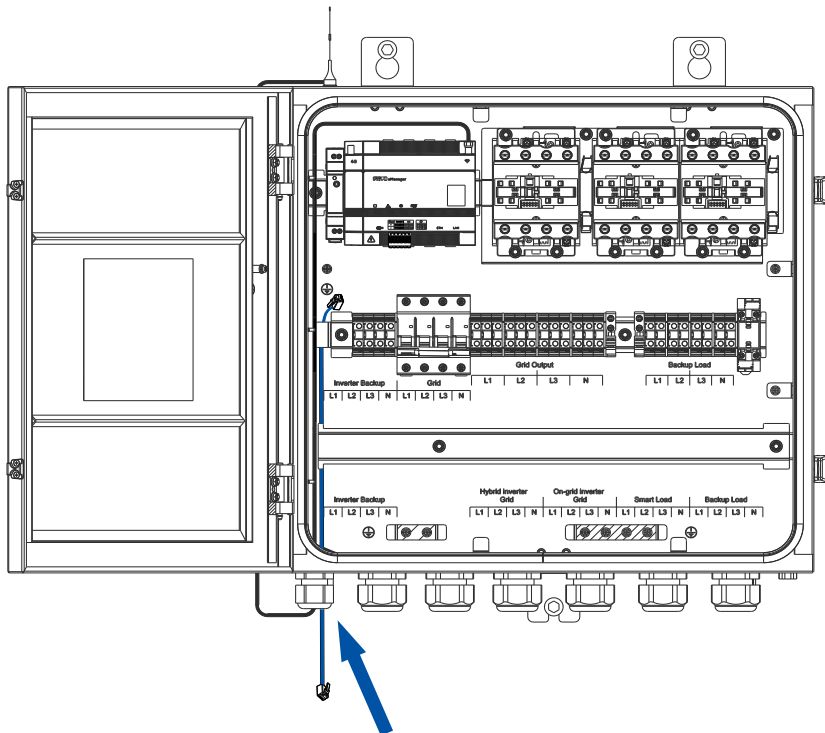

Step 4. For RS485 communication cable:

- a. Connect one end of the RJ45 plug to the negative port of the eManager communication cable.

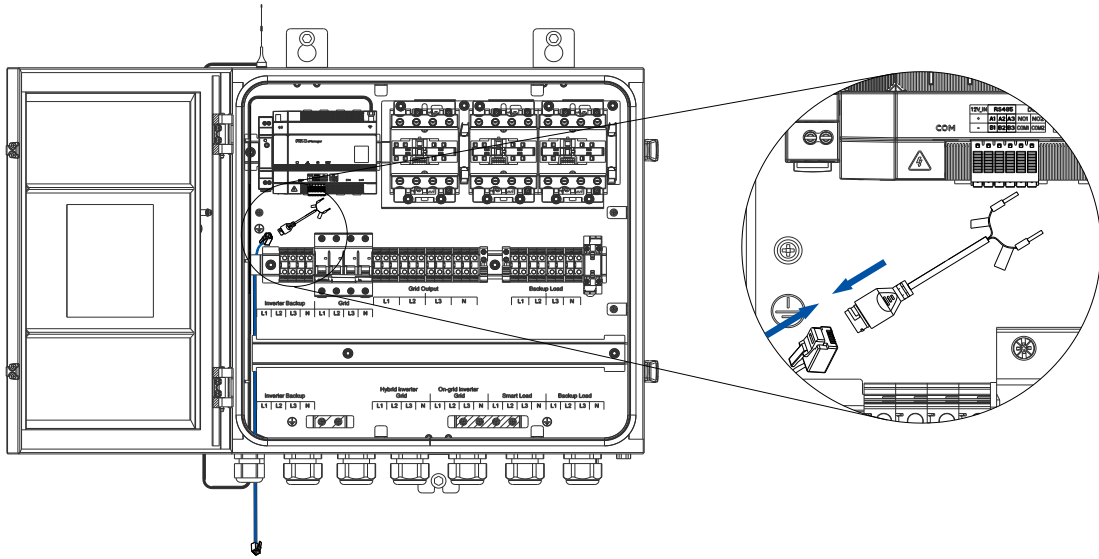

- b. Insert the other two-pin connector of the eManager communication cable to the RS485 A1/B1, A2/B2, or A3/B3 ports on the eManager module, depending on which ports are available.

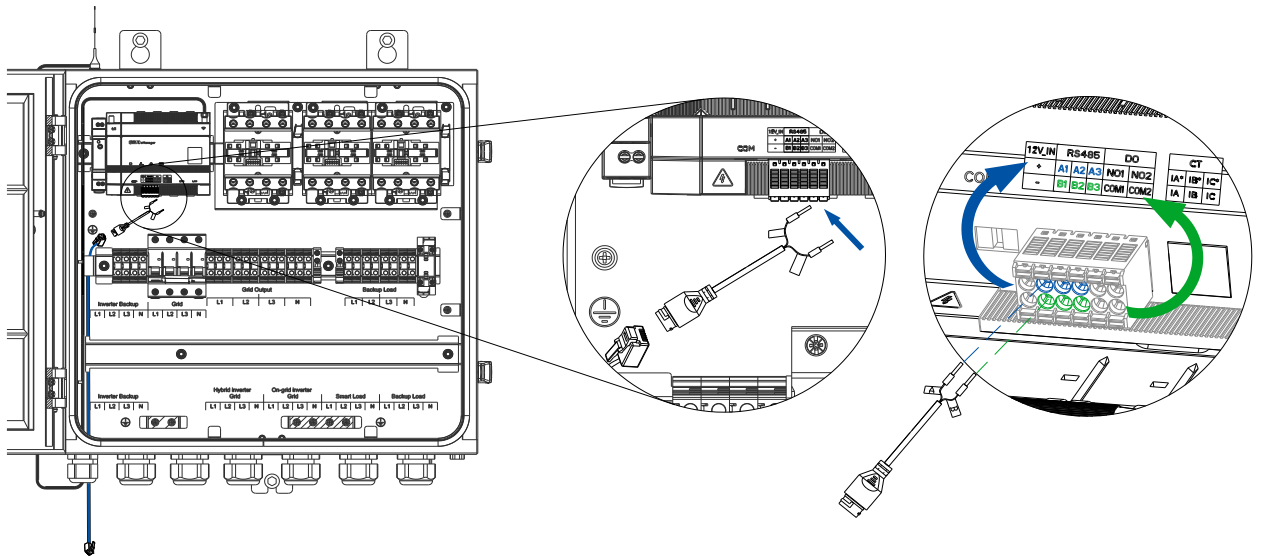

- c. Connect the other end of the communication cable to the inverter.

Step 5. For LAN connection, insert one end of the RJ45 plug into the LAN port on the eManager module; connect the other end to the communication port of the inverter.

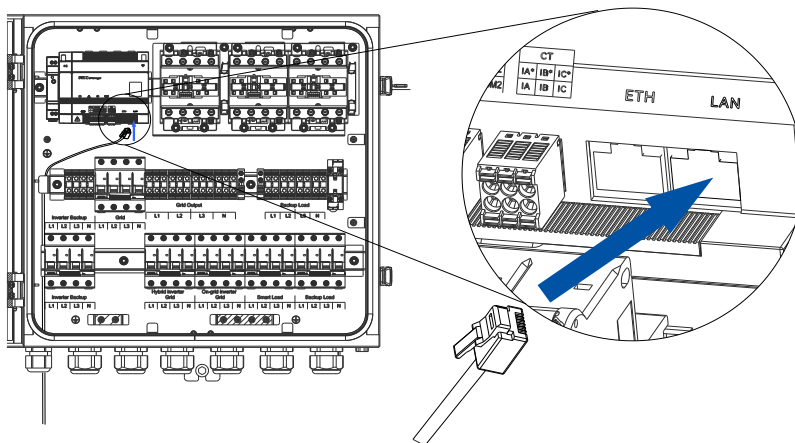

5.4 Install the circuit breakers

Step 1. Prepare the following items for the installation of circuit breakers.

- Five circuit breakers for the following connections respectively. Select applicable circuit breakers based on the rated current of the target connections.
 - Inverter Backup
 - Hybrid Inverter Grid
 - On-grid Inverter Grid
 - Smart Load
 - Backup Load
- L1, L2, L3, and N cables between the circuit breaker terminal block and the circuit breakers
 - 6-10 AWG
 - Copper core
- Tubular or crimp terminals: No longer than 5 mm in width and length. Larger terminals cannot fit into the circuit breaker terminal block. See recommended terminal type for the corresponding cables:
 - 6 AWG: E16-12
 - 8 AWG: E10-12
 - 10 AWG: E6010

Step 2. Install the circuit breakers for the ON/OFF control of Inverter Backup, Hybrid Inverter Grid, On-grid Inverter Grid, Smart Load, and Backup Load connections.

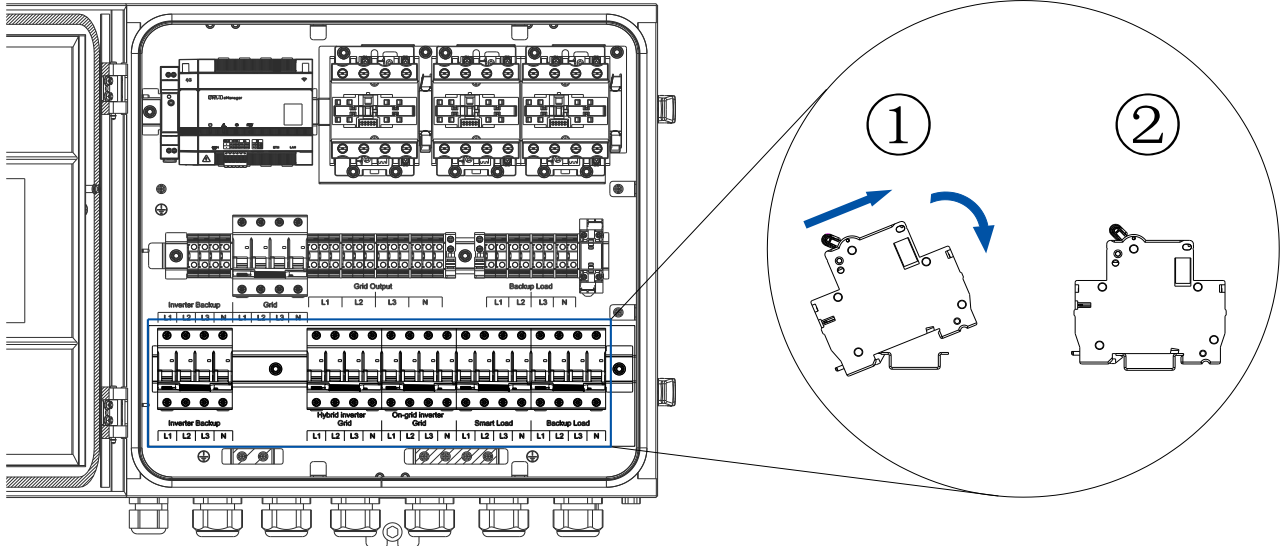

Step 3. Crimp the cable ends with the recommended terminals.

Step 4. Connect one end of the L1, L2, L3, and N cables to the circuit breaker terminal block; connect the other end of the cables to the corresponding circuit breakers:

- Connect **Inverter Backup** to **Inverter Backup**.
- Connect **Hybrid Inverter Grid**, **On-grid Inverter Grid**, and **Smart Load** to **Grid Output**. See L1 connection as an example.
- Connect **Backup Load** to **Backup Load**.

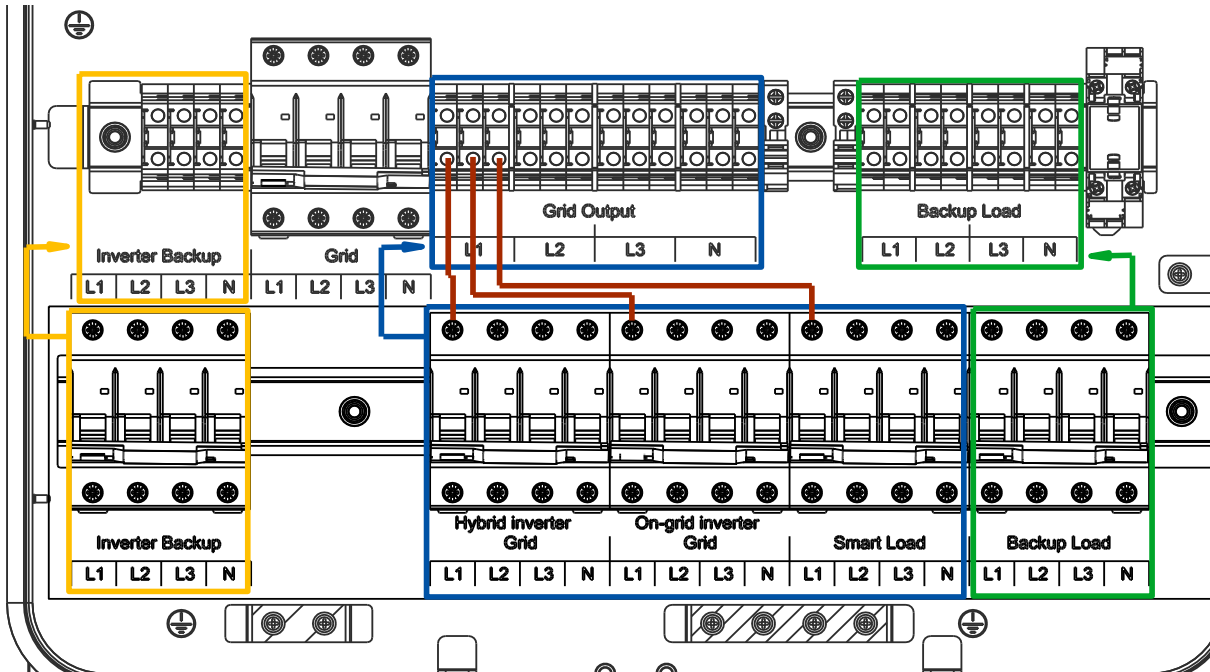

5.5 Connect the AC cables

Step 1. Prepare the AC cables and terminals according to the following specification:

- AC cables: Outer diameter (OD) of 9-25 mm; five-core copper; each core of 6-10 AWG.
- Tubular or crimp terminals for L1, L2, L3, and N cables.
- RNBS5-4 terminal for PE cables.

Step 2. Crimp the AC cable terminals with the suggested terminals. Pass the AC cables through the corresponding cable glands of **Inverter Backup**, **Hybrid Inverter Grid**, **On-grid Inverter Grid**, **Smart Load**, and **Backup Load**.

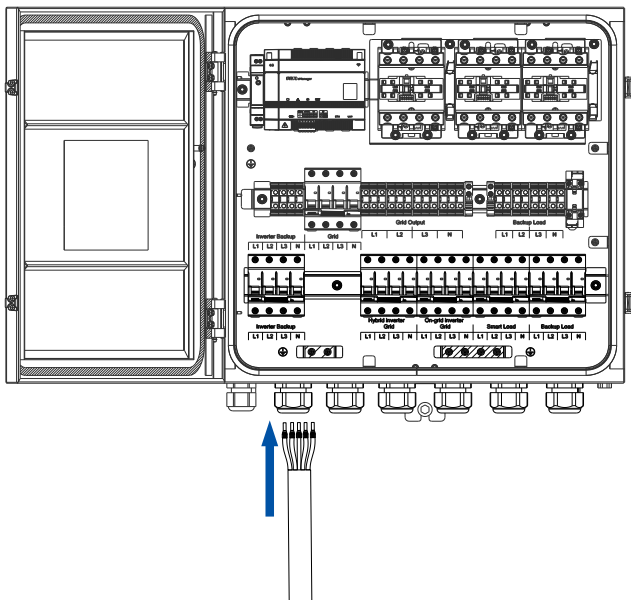

Step 3. Connect the L1, L2, L3, N, and PE cables to the corresponding ports of the circuit breakers.

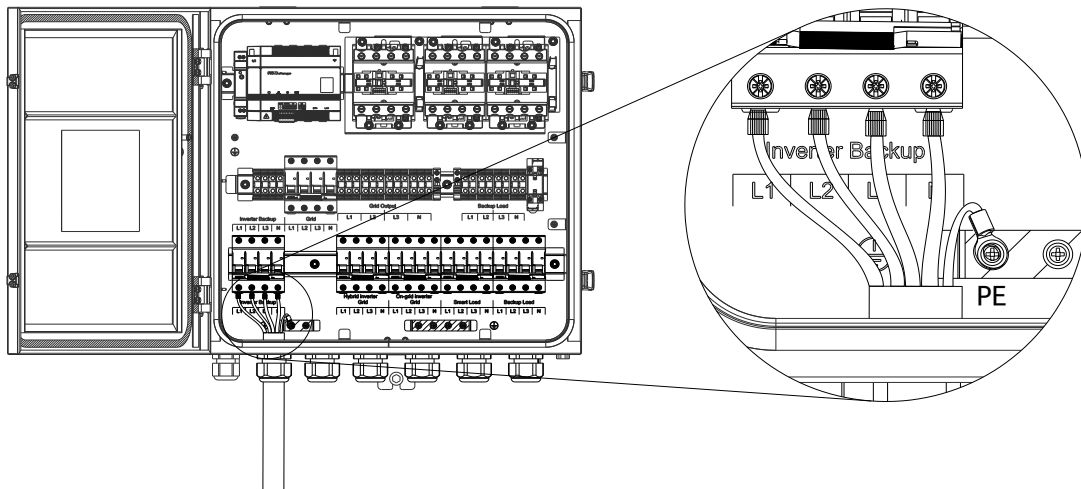

Step 4. (Optional) When the on-grid inverters are connected with the ATS box, take this step to install the current transformers (CT) if required.

- a. The user needs to prepare three 100A/50mA CTs.
- b. Install the three CTs on the L1, L2, and L3 cables of **On-grid Inverter Grid**. The CT arrows should point to the circuit breakers.

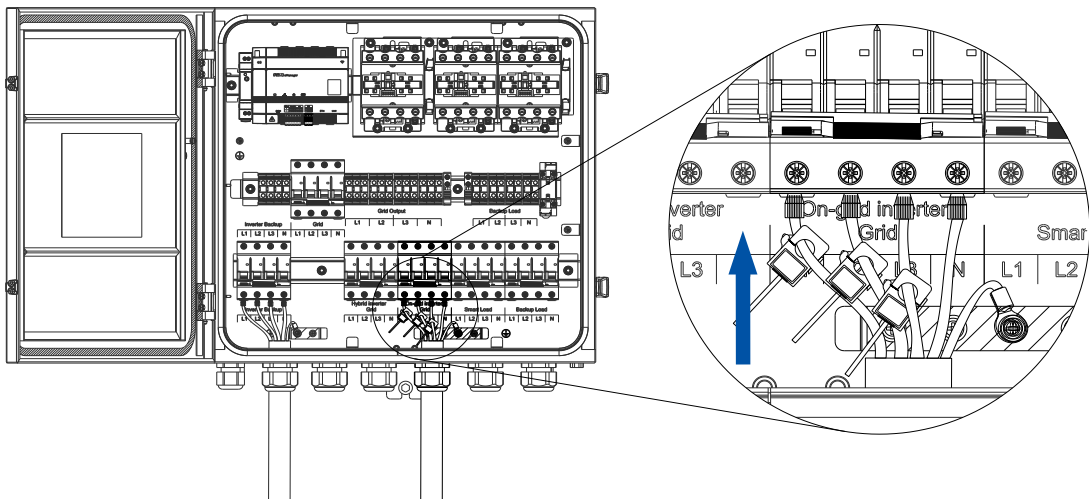

- c. Insert the 6-pin pluggable terminal into the CT port on the eManager module.

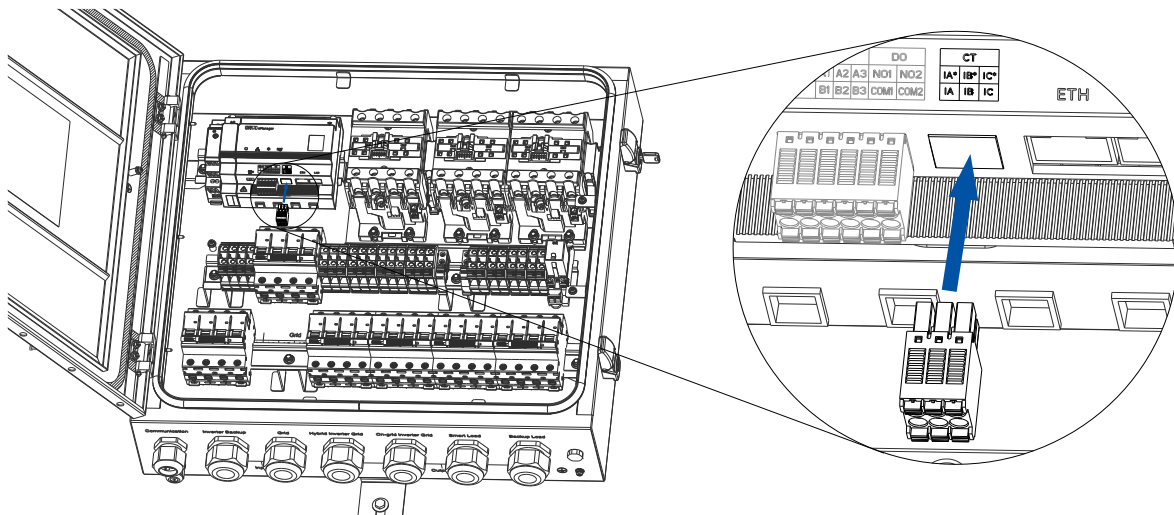

- d. Insert the positive pins of the three CTs to the **IA*** (for L1), **IB*** (for L2), and **IC*** (for L3) ports on the eManager module; insert the negative pins of the three CTs to the **IA**, **IB**, and **IC** ports.

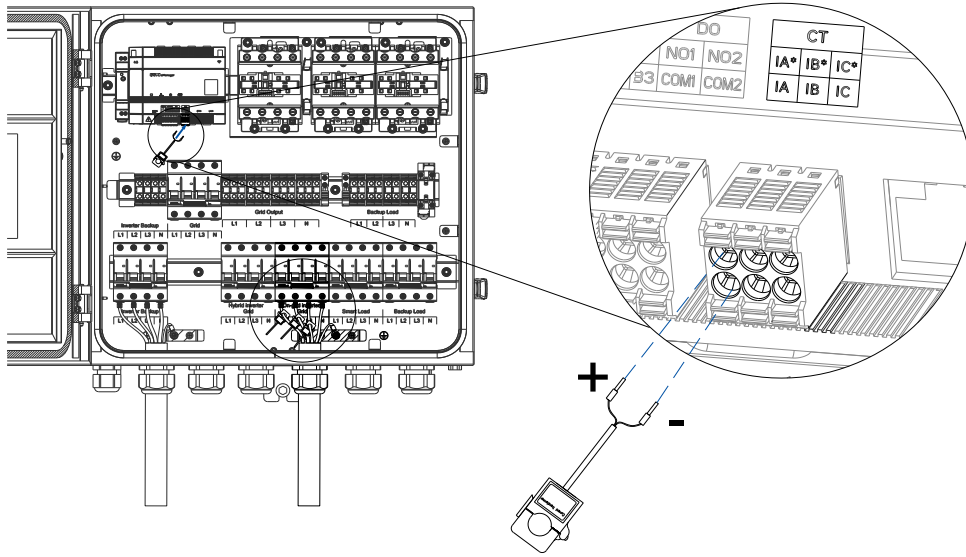

Step 5. Install the insulation cover back to the box.

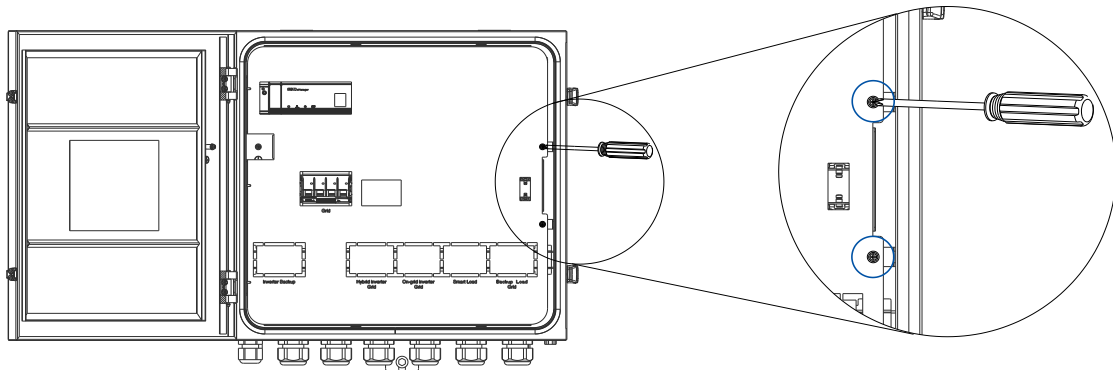

Step 6. Close and lock the box. Keep the key at a proper location.

□ 6. Commissioning on the App

When the eManager module is installed, the users can control and monitor the running status of ATS on the Elekeeper App. On your mobile phone, search for “Elekeeper” in the App store and download the App. Alternatively, you can scan the below QR code to download the App.



For detailed instructions on setting the eManager functions on the App, scan the following QR code to access the latest eManager user manual. The eManager functions are available for different SAJ inverter series with the firmware upgrade of the products.



Appendix A: Product Specification

Parameter	Model	ATS1-T63-A
AC Input (Grid)		
Grid Connection		Three-phase
Rated AC Voltage/Range [V]		220/380, 230/400, 240/415; 198-253/342-440
Rated Frequency [Hz]		50, 60
Rated Current [A]		50
Maximum Current [A]		63 ^①
AC Input (Inverter Backup)		
Rated AC Voltage/Range [V]		220/380, 230/400, 240/415; 180-280/312-485
Rated Frequency [Hz]		50, 60
Rated Current [A]		50
Maximum Current [A]		63 ^①
Inverter Connection		Three-phase
Compatible Hybrid Inverter Series		H2, HS2, HS3
AC Output (Backup Load)		
Grid Connection		Three-phase
Rated AC Voltage/Range [V]		220/380, 230/400, 240/415; 180-280/312-485
Rated Frequency [Hz]		50, 60
Rated Current [A]		50
Maximum Current [A]		63 ^②
Switching Time [ms]		50
General Parameters		
Operating Temperature Range		-25°C to +45°C
Altitude [m]		≤3000
Relative Humidity (RH)		0-95% Non-condensing
Protective Class		I
Overvoltage Category		III
Ingress Protection		IP54
Dimensions [H*W*D] [mm]		518 * 520 *141
Weight [kg]		15.8
Warranty [Year]		2
Applicable Standard		IEC/EN 61439

①② When the ambient temperature is within the range of -25°C to +30°C, the maximum current can reach 63 A. When the ambient temperature is between +30°C and +45°C, the maximum current decreases gradually from 63 A to 50 A.

Appendix B: Recycling and Disposal

This device should not be disposed as a residential waste.

An inverter that has reached the end of its operation life is not required to be returned to your dealer; instead, it must be disposed by an approved collection and recycling facility in your area.

Appendix C: Warranty and Contact Information

Warranty

Check the product warranty conditions and terms on the SAJ website: <https://www.saj-electric.com/>

Contacting Support

Guangzhou Sanjing Electric Co., Ltd.

Address: SAJ Innovation Park, No.9, Lizhishan Road, Guangzhou Science City, Guangdong, P.R.China.

Postcode: 510663

Website: <https://www.saj-electric.com/>

Technical Support & Service

Tel: +86 20 6660 8588

Fax: +86 206660 8589

E-mail: service@saj-electric.com

International Sales

Tel: 86-20-66608618/66608619/66608588/66600086

Fax: 020-66608589

E-mail: info@saj-electric.com

China Sales

Tel: 020-66600058/66608588

Fax: 020-66608589

Trademark

SAJ is the trademark of Sanjing.



GUANGZHOU SANJING ELECTRIC CO., LTD.

V0.0